

Proximity Sensors Inductive High Temperature Types IA, M5, 8, NPN/PNP

CARLO GAVAZZI



- Stainless steel housings
- Sensing distance: 0.8 - 1 mm
- Power supply: 10 to 30 VDC
- Output: Transistor NPN or PNP, make switching
- For flush mounting
- 2 m silicone cable

Product Description

Inductive proximity sensor with transistor output in M5 and M8 stainless steel housing for flush mounting in metal. Output configuration for NPN/PNP with NO as standard. Connection with 2 m silicone cable.

Ordering Key IA 05 BSF 08 NO HT-K

Type: Ind. prox. switch
 Housing style
 Housing size
 Housing material
 Housing length
 Detection principle
 Sensing distance
 Output type
 Output configuration
 High temperature

Type Selection

Rated operating dist. (S _n)	Connection type	Housing dimensions	Ordering no. Transistor NPN Make switching	Ordering no. Transistor PNP Make switching
0.8 mm	Cable, 2 m	M5	IA 05 BSF 08 NOHT-K	IA 05 BSF 08 POHT-K
1.0 mm	Cable, 2 m	M8	IA 08 BSF 10 NOHT-K	IA 08 BSF 10 POHT-K

All types for flush mounting in metal

Specifications

Rated operational volt. (U _B)	10 to 30 VDC (ripple included)	Ambient temperature	
Ripple	≤ 10%	Operating	-25 to +120°C (-13 to +248°F)
Rated operational current (I _e)		Storage	-30 to +125°C (-22 to +257°F)
Continuous	≤ 50 mA @ + 25°C (+75°F)	Degree of protection	IP 67 (Nema 1, 3, 4, 6, 13)
No-load supply current (I _o)	≤ 5 mA (ON)	Housing material	Stainless steel
Voltage drop (U _d)	< 3,0 V (@ I _{max})	CE-marking	Yes
Frequency of op. cycles (f)	Ø5: 3 kHz Ø8: 2 kHz	Connection	Cable, silicone, 2 m, AWG 26
Effective operating dist. (S _r)	0.9 x S _n ≤ S _r ≤ 1.1 x S _n		
Usable operating dist. (S _u)	0.85 x S _r ≤ S _u ≤ 1.15 x S _r		



Dimensions

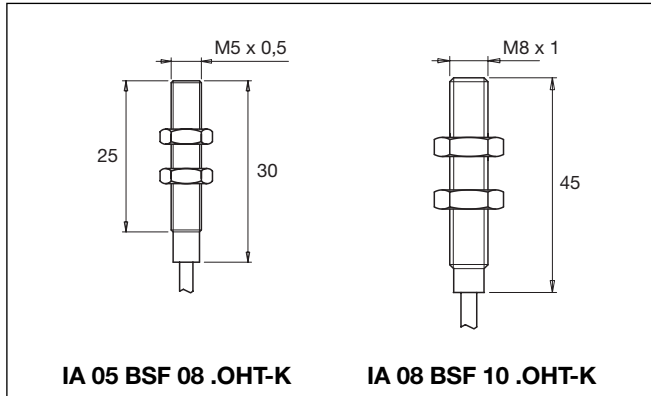

Wiring Diagrams

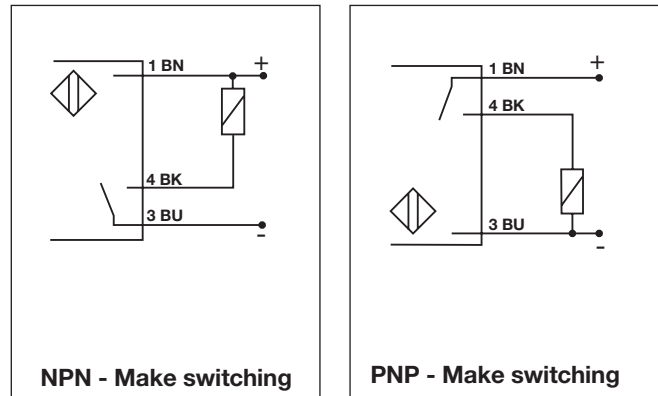

Installation Hints

