

# Dupline® Master Module Interface for Modbus-RTU Type G 3496 0005



- Interface for Modbus-RTU with the function of a slave
- Built-in normal Dupline® Channel Generator
- 128 I/O's and DC power supply on 3 wires
- 32 Analink Inputs
- RS232/RS422/RS485 port for interfacing to control system
- Multidropping of up to 16 devices on RS485
- LED-indications for supply, Dupline® carrier and Com-port TX
- Galvanically isolated Com-port supplied by internal DC/DC converter

## Product Description

G 3496 0005 is designed as a cost-effective Plug & Play solution for interfacing Dupline® I/O's to control systems. It performs three functions: Dupline® channel gen-

erator, power supply synchronization (enables 3-wire system with supply) and RS232/RS422/RS485 interface.

## Ordering Key

**G 3496 0005 700**

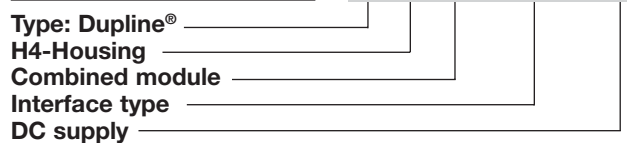

## Type Selection

Supply	PLC Interface Conformance	Ordering no.
20-30 VDC	Modbus-RTU, Function code 01, 02, 03, 04, 05, 06 & 16	<b>G 3496 0005 700</b>

## Input/Output Specifications

<b>Power output</b>	
Output voltage	20-30 VDC (pulsating)
Output current	< 3.0 A @ 50°C
Short circuit protection	4 A quick acting fuse
Output voltage drop	< 1.0 V
<b>Dupline® carrier</b>	
Output voltage	8.2 V (pulsating)
Current	< 60 mA
Short circuit protection	Yes
Scan time	
128 channels	132.2 ms
64 channels	69.8 ms
<b>Communication port</b>	
Standard	RS 232/RS 422/ RS 485
Split I/O / Normal mode	Normal mode
Connection	9 pole female SUB-D
Dielectric voltage	
Com-port - Dupline®	1 kVAC (rms)
Protocol	Modbus-RTU
Baud rate	9600
Data bits	8
Start bit	-
Stop bit	1
Parity	None
Flow-control	None

## Input/Output Specifications (Cont.)

<b>Pin assignment</b>	
2-wire RS 485	
S/R Data line + (B)	Pin 3
S/R Data line - (A)	Pin 8
GND	Pin 5
4-wire RS 485/RS 422	
R Data line + (B)	Pin 3
R Data line - (A)	Pin 8
S Data line + (B)	Pin 2
S Data line - (A)	Pin 7
Direction	Pin 4
	(Connect to GND pin 5 when using 4-wire communication)
RS 232	
TX	Pin 1
RX	Pin 9
GND	Pin 5

## Supply Specifications

<b>Power supply</b>	
Operational voltage (V <sub>in</sub> )	Overvoltage cat. III (IEC 60664)
Reverse polarity protection	20-30 VDC
Current consumption	None
Power dissipation	< 150 mA + Power load
Transient protection voltage	< 5 W
Dielectric voltage	800 V
Supply - Dupline®	None
Supply - com-port	1 kVAC (rms)

## General Specifications

<b>Power ON delay</b>	2 s	<b>Humidity (non-condensing)</b>	20 to 80%
<b>Indication for</b>		<b>Mechanical resistance</b>	
Com-port Tx	LED, red	Shock	15 G (11 ms)
Supply ON	LED, green	Vibration	2 G (6 to 55 Hz)
Dupline® carrier	LED, yellow	<b>Dimensions</b>	H4-Housing
<b>Environment</b>		<b>Material</b>	(see Technical information)
Pollution degree	3 (IEC 60664)	<b>Weight</b>	100 g
Operating temperature	0° to +50°C (+32° to +122°F)		
Storage temperature	-50° to +85°C (-58° to +185°F)		

## Mode of Operation

The Dupline® Master Module is a Dupline® Channel Generator with the function of a slave. This means that the 128 Dupline® I/O's can be read/controlled by a PC/PLC or a Control board master from many different suppliers. Up to

16 Dupline® DMM can be connected to the same network and operate together with other modules using the same protocol like operator panels, MMI's frequency inverters, I/O-modules etc.

## Dip-Switch Setting

- Sw.1-4 On/Off:** Device no. 1-16 (all off = 16)
- Sw.5 On:** 64 Dupline® channels
- Sw.5 Off:** 128 Dupline® channels
- Sw.6 On:** Maintain data to Dupline® receivers in case of communication failure
- Sw.6 Off:** Clear data to Dupline® receivers in case of communication failure after 75 Dupline scans

Device no.	Sw1	Sw2	Sw3	Sw4
01	0	0	0	1
02	0	0	1	0
03	0	0	1	1
04	0	0	1	0
-				
15	1	1	1	1
16	0	0	0	0

## Wiring Diagrams

### Multidrop

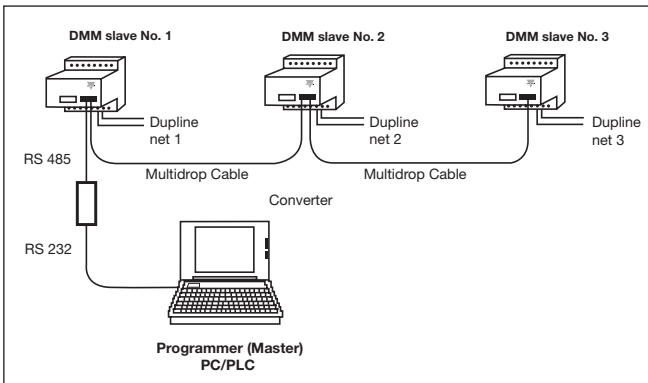

### Peer to Peer

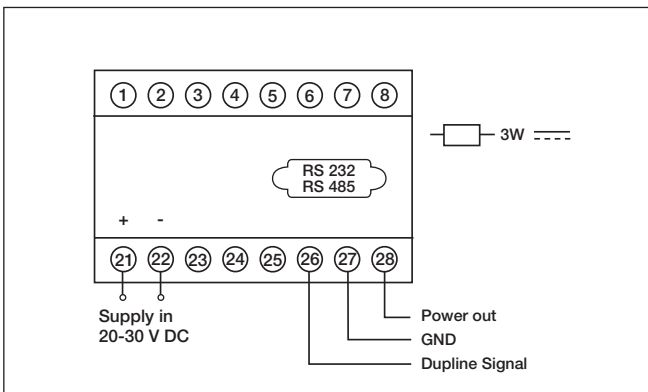
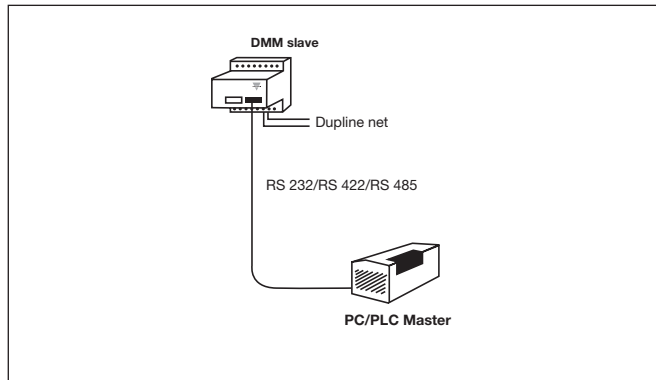

## Telegram Structure

### Modbus-RTU Function code 01: Read Output Table (Data to receivers) or 02: Read Input Table (Data from transmitters)

Field Name	Example (HEX)	Description
Slave Address	07	Addressed to DMM no. 7
Function	01/02	Read Output/Input Table
Starting Point no. Hi	00	Read Dupline® A6
Starting Point no. Lo	05*	(Point no. 6)
Number of points	00	Always 00 01
Number of points	01	
Error Check	XX XX	-

### Response Message

Field Name	Example (HEX)	Description
Slave Address	07	Addressed from DMM no. 7
Function	01/02	Read Output/Input Table
Byte Count	01	1 byte
Data	01	Dupline® Channel A6 (ON)
Error Check	XX XX	-

### Modbus-RTU Function Code 03: Read Holding Registers Query message

Field Name	Example (HEX)	Description
Slave Address	07	Addressed to DMM no. 7
Function	03	Read Registers
Starting Address Hi	00	Starting register no. 0
Starting Address Lo	00*	
Number of registers Hi	00	Read 5 Registers (Group A-J)
Number of registers Lo	05	
Error Check	XX XX	-

### Response Message

Field Name	Example (HEX)	Description
Slave Address	07	Addressed from DMM no. 7
Function	03	Read Registers
Byte Count	0A	10 bytes (5 Registers)
Data Hi Register no. 1	00	Dupline® Group B
Data Lo Register no. 1	40	Dupline® Group A (A7 ON)
-----		
Data Hi Register no. 5	00	Dupline® Group J
Data Lo Register no. 5	00	Dupline® Group I
Error Check	XX XX	-

### Modbus-RTU Function Code 16: Write Multiple Registers Query Message

Field Name	Example (HEX)	Description
Slave Address	07	Addressed to DMM no. 7
Function	10	Write Registers
Starting Address Hi	00	Starting Register no. 0
Starting Address Lo	00*	
Number of registers Hi	00	Write 5 Registers (Group A-J)
Number of registers Lo	05	
Byte Count	0A	10 bytes (5 Registers)
Data Hi Register 1	02	Dupline® Group B (B2 ON)
Data Lo Register 1	00	Dupline® Group A
-----		
Data Hi Register 5	00	Dupline® Group J
Data Lo Register 5	00	Dupline® Group I
Error Check	XX XX	-

### Response Message

Field Name	Example (HEX)	Description
Slave Address	07	Addressed from DMM no. 7
Function	10	Write Registers
Starting Address Hi	00	Starting register no. 0
Starting Address Lo	00*	
Number of registers Hi	00	Write 5 Registers (Group A-J)
Number of registers Lo	05	
Error Check	XX XX	-

\* According to modbus protocol definition the starting address/point is transferred as one less than the number of the first reg/point to be read/written to

## Memory Mapping

### Read Output Table (01). Read Input Table (02) and Force Single Output (05)

Point no.	Dupline® Channel
1	A1
2	A2
3	A3
-	-
128	P8

**Digital read (Modbus Function 03) and Digital Write (Modbus Function 16)**

Reg. no.	HIGH BYTE								LSB	LOW BYTE								LSB
	MSB	B8	B7	B6	B5	B4	B3	B2	B1	MSB	A8	A7	A6	A5	A4	A3	A2	A1
1	B8	B7	B6	B5	B4	B3	B2	B1	A8	A7	A6	A5	A4	A3	A2	A1		
2	D8	D7	D6	D5	D4	D3	D2	D1	C8	C7	C6	C5	C4	C3	C2	C1		
3	F8	F7	F6	F5	F4	F3	F2	F1	E8	E7	E6	E5	E4	E3	E2	E1		
4	H8	H7	H6	H5	H4	H3	H2	H1	G8	G7	G6	G5	G4	G3	G2	G1		
5	J8	J7	J6	J5	J4	J3	J2	J1	I8	I7	I6	I5	I4	I3	I2	I1		
6	L8	L7	L6	L5	L4	L3	L2	L1	K8	K7	K6	K5	K4	K3	K2	K1		
7	N8	N7	N6	N5	N4	N3	N2	N1	M8	M7	M6	M5	M4	M3	M2	M1		
8	P8	P7	P6	P5	P4	P3	P2	P1	O8	O7	O6	O5	O4	O3	O2	O1		
129									A1	A2	A3	A4	A5	A6	A7	A8		
130									B1	B2	B3	B4	B5	B6	B7	B8		
131									C1	C2	C3	C4	C5	C6	C7	C8		
132									D1	D2	D3	D4	D5	D6	D7	D8		
-									-	-	-	-	-	-	-	-	-	-
144									P1	P2	P3	P4	P5	P6	P7	P8		

**Analink read (Modbus Function 03) – 32 Analink Inputs**

Reg no.	MSB HIGH BYTE	LSB	MSB LOW BYTE	LSB
9	Analink value 0-255 from A2		Analink value 0-255 from A1	
10	Analink value 0-255 from A4		Analink value 0-255 from A3	
11	Analink value 0-255 from A6		Analink value 0-255 from A5	
12	Analink value 0-255 from A8		Analink value 0-255 from A7	
13	Analink value 0-255 from B2		Analink value 0-255 from B1	
14	Analink value 0-255 from B4		Analink value 0-255 from B3	
15	Analink value 0-255 from B6		Analink value 0-255 from B5	
16	Analink value 0-255 from B8		Analink value 0-255 from B7	
17	Analink value 0-255 from C2		Analink value 0-255 from C1	
18	Analink value 0-255 from C4		Analink value 0-255 from C3	
19	Analink value 0-255 from C6		Analink value 0-255 from C5	
20	Analink value 0-255 from C8		Analink value 0-255 from C7	
21	Analink value 0-255 from D2		Analink value 0-255 from D1	
22	Analink value 0-255 from D4		Analink value 0-255 from D3	
23	Analink value 0-255 from D6		Analink value 0-255 from D5	
24	Analink value 0-255 from D8		Analink value 0-255 from D7	
145			Analink value 0-255 from A1	
146			Analink value 0-255 from A2	
147			Analink value 0-255 from A3	
148			Analink value 0-255 from A4	
149			Analink value 0-255 from A5	
150			Analink value 0-255 from A6	
-	-		-	
175			Analink value 0-255 from P7	
176			Analink value 0-255 from P8	

**Installation Hints**

**No TX-LED**

**Checksum Error**

**Wrong telegram structure**

**Hardware fault**

The Checksum has been calculated in a wrong way.

See "Telegram Structure"

Check the wiring. Try to send the telegram-example mentioned in "Telegram Structure."

**No Dupline® Carrier-Led**

**Short circuit**

Short circuit between the two Dupline® wires.

**Dimensions (mm)**

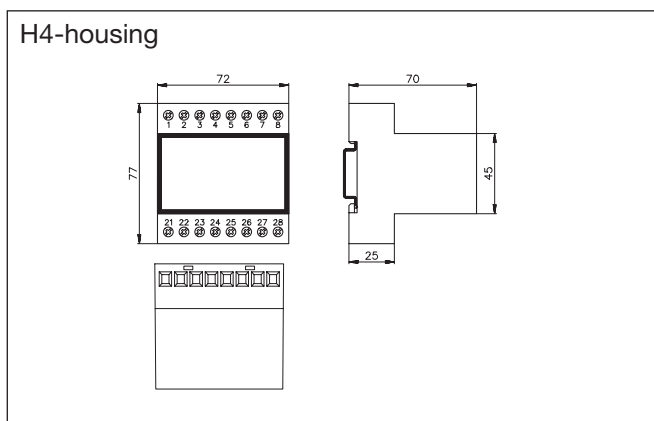

**Accessories**

Support Disc Download the Support Disc from our homepage [www.dupline.com](http://www.dupline.com)

**Additional Information**

**Scope of supply**

1 x Master Module G3496 0005 700