

control desks

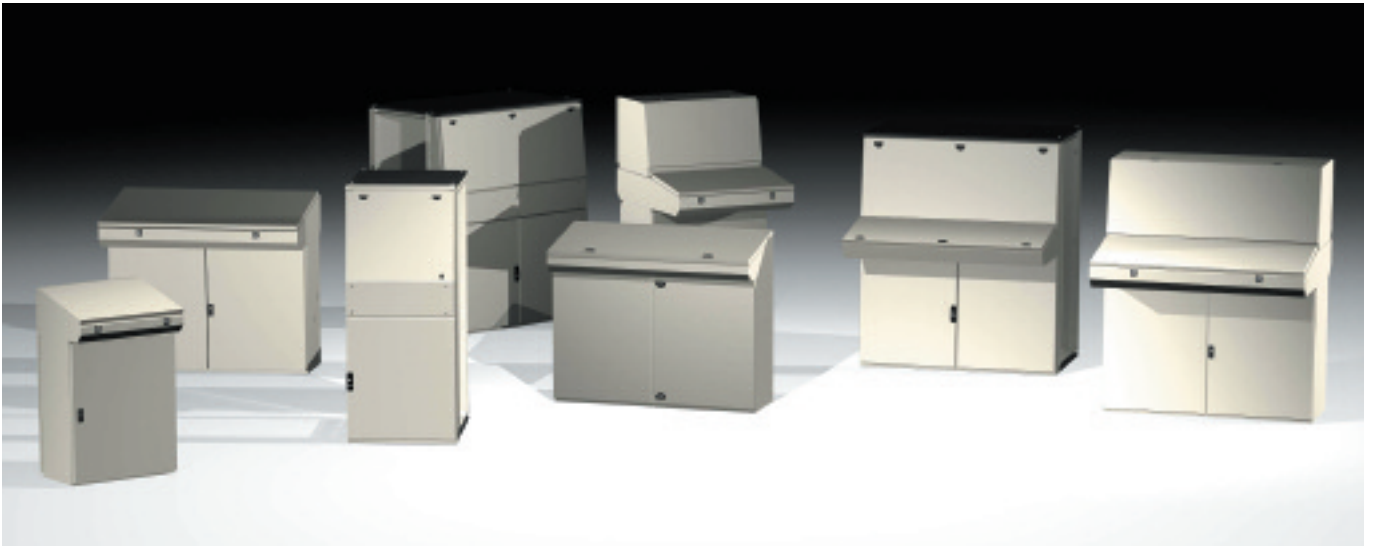

control desks

ETA's range of control desks satisfies the most demanding customer requirements. Of elegant simple lines they allow the user to tailor the unit to suit the technical and constructional aspects of applications where control desks are used on equipment or machines.

There are three styles in the range: a modular, sectional assembly, a one-piece construction and a desk cabinet.

The sectional desk can be made up from a number of elements: base, 2 types of shelf, console, plinth and cover, offering a very flexible arrangement to suit individual needs.

The one-piece desk is used in simpler applications but still offers an up-to-date technical specification.

These styles have bottom entry gland plates with an adjustable, removable section and an adjustable mounting plate.

Accessories are common to three styles. The shelf lid of LE-ME and SBA are supplied with gas springs.

The design concept of the PE console allows the installation of racks or monitors and a supplementary casing can be fitted to the back to increase the usable depth to 500mm.

The cabinet desks are manufactured from pressbent and welded 1.5mm and 2mm sheet steel.

The ZBA control desk range has been manufactured in parallel to the SBA range to meet simpler applications.

Areta AL

Is an evolution of the Areta range and offers the same concept as the Areta PC: a frontal frame mounted on the basic Areta structure. The range includes:

- upper door with mechanical stop avoiding accidental closing
 - lower door
 - centre section that allows the application of a blank panel or desk shelf with lid and gas stays.
- Areta AL desk cabinets are available in 4 widths and 2 depths; the maximum height of 1400mm allows good viewing access for monitors and other visual components.

AVAILABLE FULLY ASSEMBLED AND FLAT-PACK.



Areta AL desk cabinets

The AL desk cabinet range offers the versatility already suggested by the pc range: a front frame mounted on the basic Areta structure.

characteristics

- 4 widths
- 2 depths
- maximum height of 1400mm which allows a good usable area
- a vast range of accessories.

paint finish

ETA standard epoxy polyester powder coating.

Colour: RAL 7032 textured finish.

Roof and bottom: RAL 7025 textured finish.

protection degree

- IP 55 complying with EN50298; EN60529.

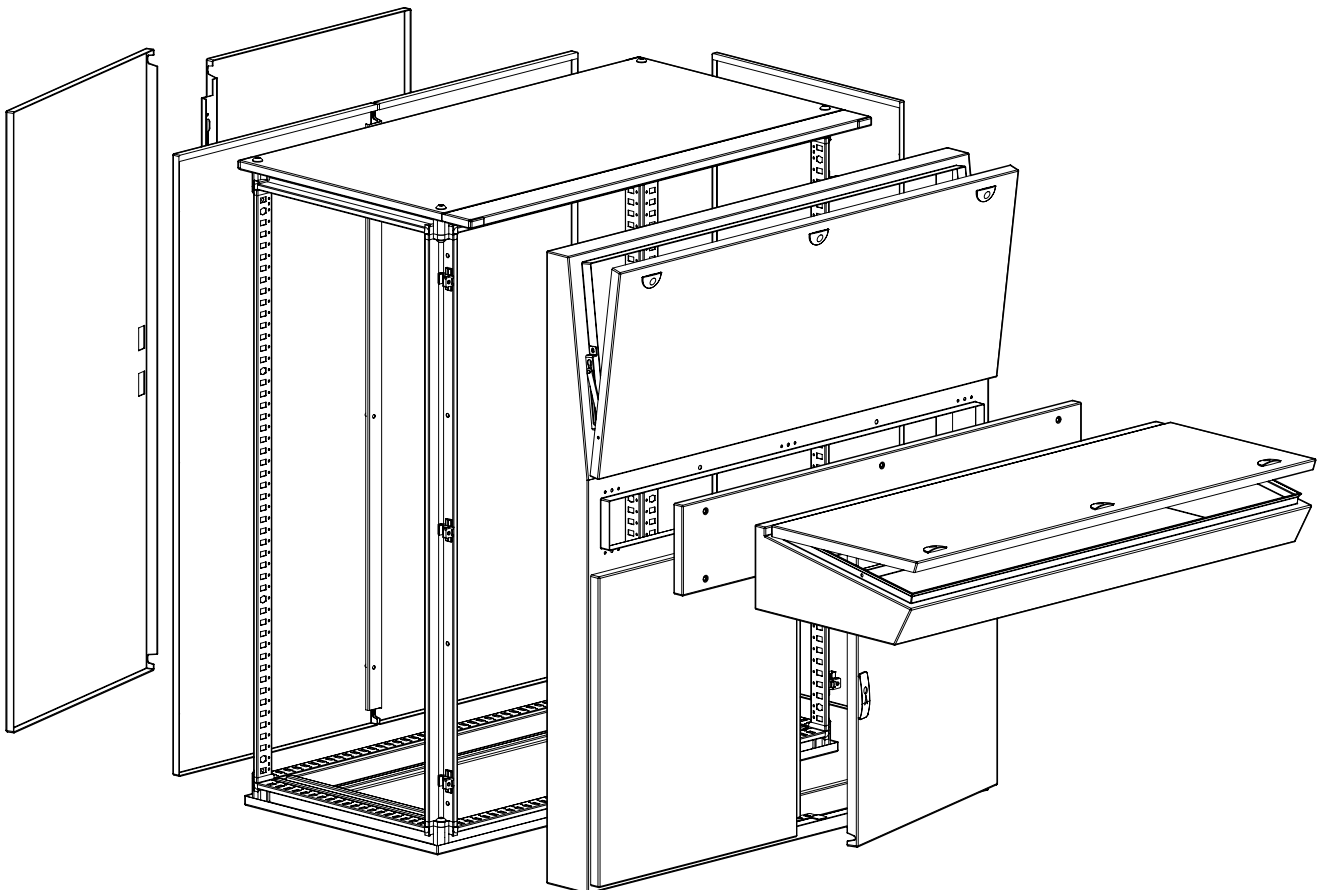



Areta AL desk cabinets

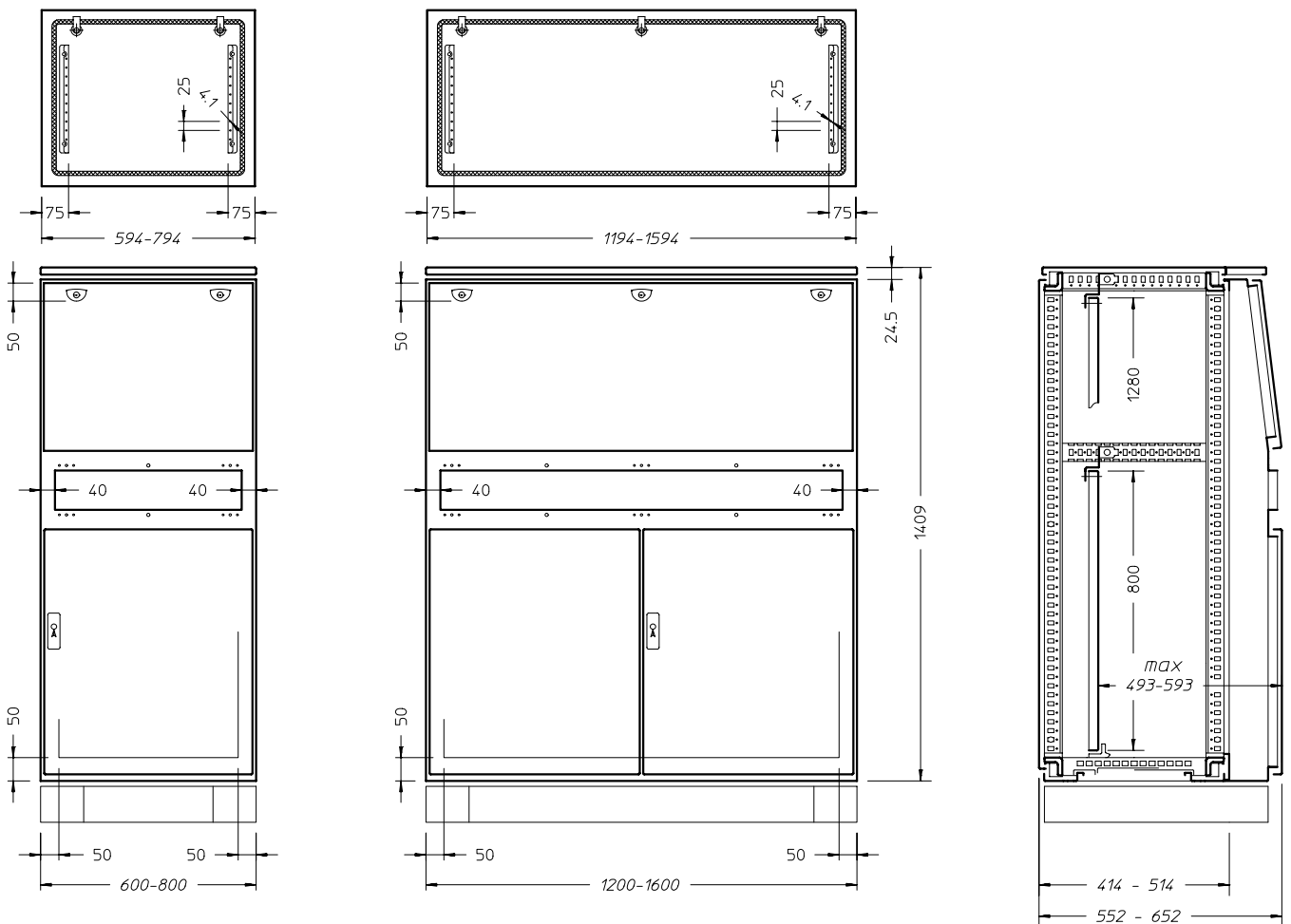



Areta AL desk cabinets

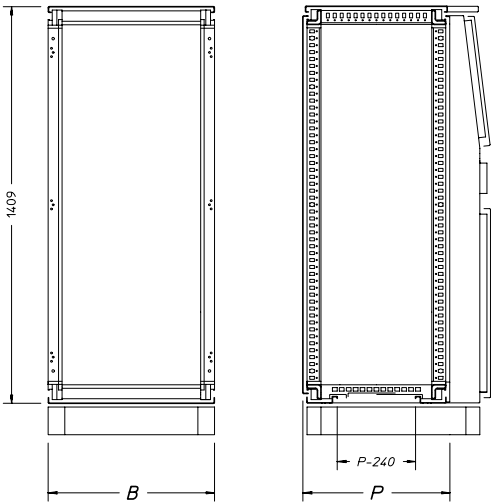

ARETA AL MOUNTED CABINET characteristics

- Areta structure with rear door or panel
- AL structure.

To be ordered separately:

- lateral panels (see page 71)
- shelf or front panel (see page 209).

ARETA AL mounted with rear door

code		cabinet width	
mod.	art.	width	depth
ATAL	061404FP	600	400
	081404FP	800	
	121404FP	1200	
	161404FP	1600	
	061405FP	600	500
	081405FP	800	
	121405FP	1200	
	161405FP	1600	

ARETA AL mounted with rear panel

code		cabinet width	
mod.	art.	width	depth
ATAL	061404FR	600	400
	081404FR	800	
	121404FR	1200	
	161404FR	1600	
	061405FR	600	500
	081405FR	800	
	121405FR	1200	
	161405FR	1600	

characteristics

Frame manufactured from 2mm sheet steel.

Upper door manufactured from 1.5mm sheet with sendzimir profiles and mechanical stop avoiding accidental closing and Ø 3mm double bar locking system. Lower door manufactured from 1.5mm sheet steel with stiffening profile and Ø 3mm double bar latch closing system.

- adhesive gasket and mounting accessories
- a pair of structural uprights.

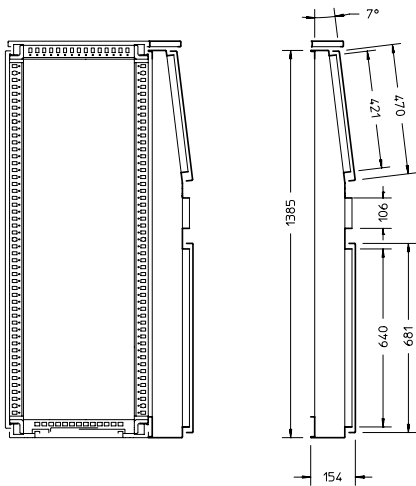

flat-pack Areta AL cabinet

dimensions			roof + bottom	front structure (*)	door (*)	rear panel (*)
width	height	depth				
600	1400	400	ATTF-060040	ATAL-060140	ATPO-060140	ATRE-060140
600	1400	500	ATTF-060050	ATAL-060140	ATPO-060140	ATRE-060140
800	1400	400	ATTF-080040	ATAL-080140	ATPO-080140	ATRE-080140
800	1400	500	ATTF-080050	ATAL-080140	ATPO-080140	ATRE-080140
1200	1400	400	ATTF-120040	ATAL-120140	ATPO-120140	ATRE-120140
1200	1400	500	ATTF-120050	ATAL-120140	ATPO-120140	ATRE-120140
1600	1400	400	ATTF-160040	ATAL-160140	ATPO-160140	ATRE-160140
1600	1400	500	ATTF-160050	ATAL-160140	ATPO-160140	ATRE-160140

(*) AL front structure, rear doors, rear panels are supplied together with a pair of uprights.

To be ordered separately:

- shelf or front panel (see page 209)
- lateral panels (see page 71)
- inner mounting plate (see page 210).

accessories

SHELF ATME

characteristics

Structure manufactured from 1.5mm sheet steel.
Upper panel manufactured from 1.5mm sheet steel with sendzimir rails and gas springs
avoiding accidental closing.

supply includes

- one shelf
- upper panel complete with \varnothing 3mm double bar locking system
- sealing gasket
- mounting accessories.

shelf

code		cabinet width
mod.	art.	
ATME	000600AL	600
	000800AL	800
	001200AL	1200
	001600AL	1600

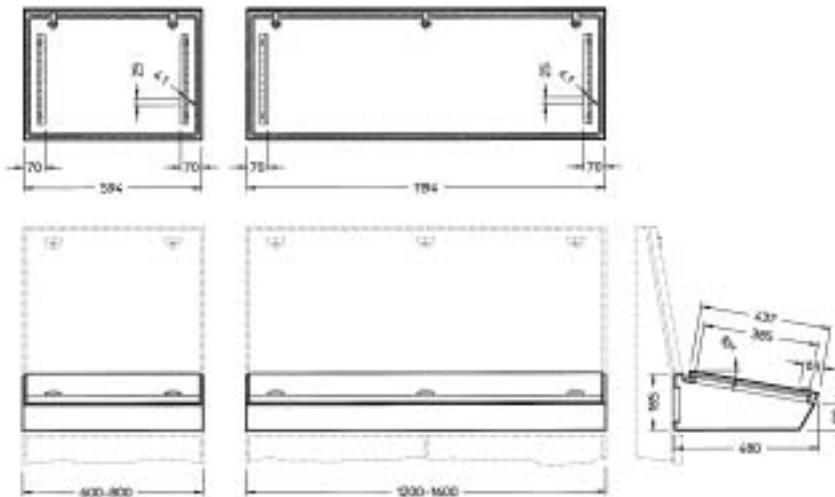

PANEL ATPN

Manufactured from 1.5mm sheet steel.
Colour: RAL 7032 textured finish.
Supply includes: mounting accessories.

panel

code		cabinet width
mod.	art.	
ATPN	000600AL	600
	000800AL	800
	001200AL	1200
	001600AL	1600



accessories

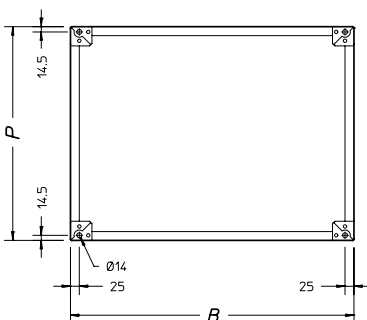
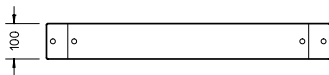
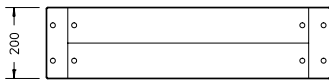
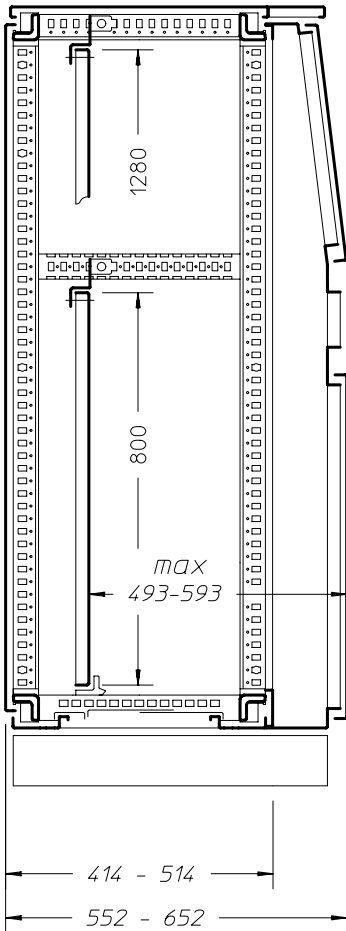

MOUNTING PLATE H=800 ATRP

Manufactured from 2.5mm sendzimir sheet steel.

To be ordered separately:

- lateral rails and mounting accessories (see page 112).

code		cabinet width
mod.	art.	
ATPR	060080	600
	080080	800
	120080	1200
	160080	1600

RAILS WTPR

Supply includes: 2 pieces, mounting accessories.

To be ordered separately:

- mounting accessories WTSP - 001CP.

code		cabinet depth
mod.	art.	
WTPR	050040CP	400
	050050CP	500
	050060CP	600
	050080CP	800

MOUNTING PLATE H=1300 ATPA

Manufactured from 2.5mm sendzimir sheet steel for L<1000, 3mm for L 1000.

To be ordered separately:

- mounting accessories (see page 66).

code		cabinet width
mod.	art.	
ATPA	060140	600
	080140	800
	120140	1200
	160140	1600

For L 1400 mounting plate manufactured with two parts with horizontal union and stiffening omega.

PLINTH H=100 ATZ4 - H=200 ATZ5

Colour RAL 7025 textured finish.

code		cabinet dimensions		plinth	
mod.	art.	width	depth	B	P
ATZ4 (h=100)	060040	600	414	600	503
	080040	800		800	
	120040	1200		1200	
	160040	1600		1600	
ATZ5 (h=200)	060050	600	514	600	603
	080050	800		800	
	120050	1200		1200	
	160050	1600		1600	



Albavilla: external view of the warehouse and inner views of the stock.

modular control desks 400mm depth

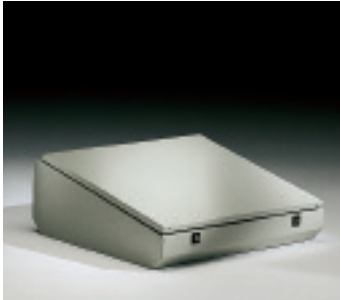

SHELF ME

characteristics

Structure manufactured from 1.5mm pressbent sheet steel.
Upper panel manufactured from 2mm sheet steel with zincpassivated rails.
Gas springs to support lid.

supply includes

- control desk
- lid complete with Ø 3mm closing system
- sealing gasket
- mounting accessories.

code		width
mod.	art.	
ME 6	01	600
ME 8	02	800
ME 1	23	1200
ME 1	64	1600



UPPER PART PE

characteristics

Structure manufactured from 1.5mm pressbent sheet steel.
Mounting plate manufactured from 2.5mm sheet steel with zincpassivated 2mm rails for mounting plate adjustment.
Hinged front panel manufactured from 2mm sheet steel complete with zincpassivated vertical rails and mechanical stop.

supply includes

- upper part
- hinged front cover with Ø 3mm double bar key
- mounting plate
- sealing gasket
- mounting accessories.

code		width
mod.	art.	
PE 6	01	600
PE 8	02	800
PE 1	23	1200
PE 1	64	1600



SHELF LE

characteristics

Structure manufactured from 1.5mm pressbent sheet steel.
Upper panel manufactured from 2mm sheet steel with zincpassivated rails.
Gas springs to support lid.

supply includes

- control desk
- lid complete with Ø 3mm closing system
- rails to mount supplementary mounting plate
- sealing gasket
- mounting accessories.

code		width
mod.	art.	
LE 6	01	600
LE 8	02	800
LE 1	23	1200
LE 1	64	1600



BOX AE

characteristics

Structure manufactured from 1.5mm pressbent sheet steel.
Mounting plate manufactured from 2.5mm sheet steel.
Door manufactured from 1.5mm sheet steel with lateral stiffening cover.

supply includes

- AE box
- door complete with Ø 3mm double door closing system
- mounting plate
- adjustable gland plate.

code		width
mod.	art.	
AE 6	01	600
AE 8	02	800
AE 1	23	1200
AE 1	64	1600

paint finish

ETA standard epoxy polyester powder coating.
RAL 7032 textured finish.

conformity and approval



protection degree

- IP 55 complying with EN60529
- type 12 complying with UL508A; UL50.

modular control desks 500mm depth

code		width
mod.	art.	
ME 8	025	800
ME 1	235	1200
ME 1	645	1600

SHELF ME characteristics

Structure manufactured from 1.5mm pressbent sheet steel.
Upper panel manufactured from 2mm sheet steel with zincpassivated rails.
Gas springs to support lid.

supply includes

- control desk
- lid complete with Ø 3mm closing system
- sealing gasket
- mounting accessories.

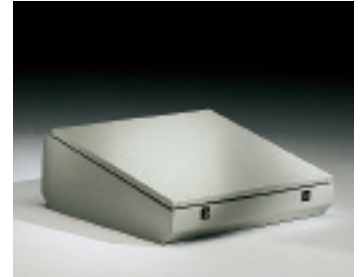

code		width
mod.	art.	
PE 8	025	800
PE 1	235	1200
PE 1	645	1600

UPPER PART PE characteristics

Structure manufactured from 1.5mm pressbent sheet steel.
Mounting plate manufactured from 2.5mm sheet steel with zincpassivated 2mm rails for mounting plate adjustment.
Hinged front panel manufactured from 2mm sheet steel complete with zincpassivated vertical rails and mechanical stop.

supply includes

- upper part
- hinged front cover with Ø 3mm double bar key
- mounting plate
- sealing gasket
- mounting accessories.

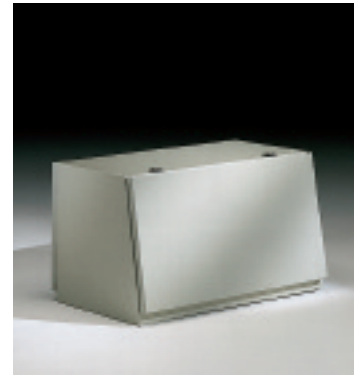

code		width
mod.	art.	
LE 8	025	800
LE 1	235	1200
LE 1	645	1600

SHELF LE characteristics

Structure manufactured from 1.5mm pressbent sheet steel.
Upper panel manufactured from 2mm sheet steel with zincpassivated rails.
Gas springs to support lid.

supply includes

- control desk
- lid complete with Ø 3mm closing system
- rails to mount supplementary mounting plate
- sealing gasket
- mounting accessories.

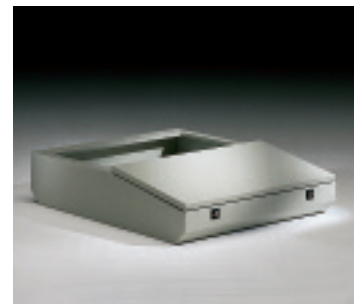

code		width
mod.	art.	
AE 8	025	800
AE 1	235	1200
AE 1	645	1600

BOX AE characteristics

Structure manufactured from 1.5mm pressbent sheet steel.
Mounting plate manufactured from 2.5mm sheet steel.
Door manufactured from 1.5mm sheet steel with lateral stiffening cover.

supply includes

- AE box
- door complete with Ø 3mm double door closing system
- mounting plate
- adjustable gland plate.



paint finish
ETA standard epoxy polyester powder coating.
RAL 7032 textured finish.

conformity and approval



protection degree

- IP 55 complying with EN60529
- type 12 complying with UL508A; UL50.

modular control desks 400mm depth dimensions

LE + PE

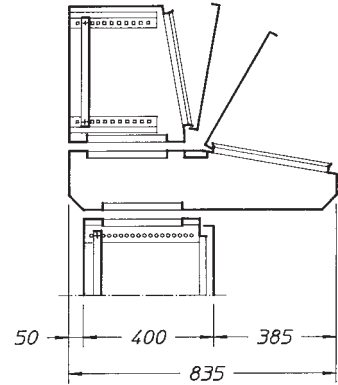
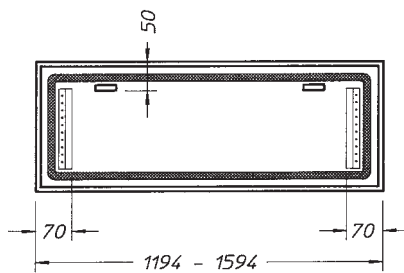
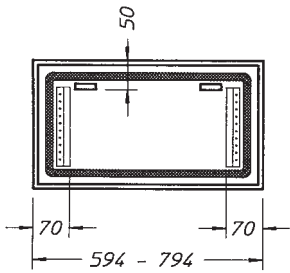

PE

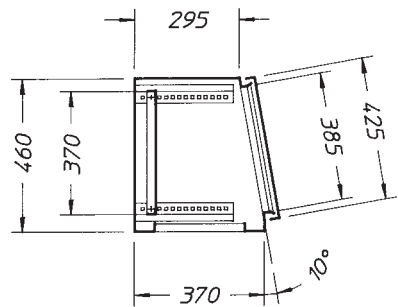

LE

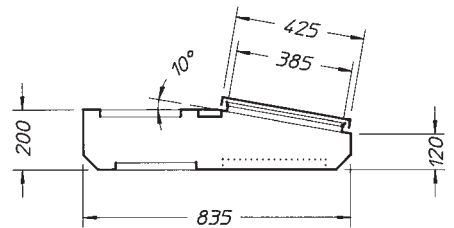
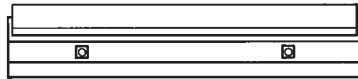
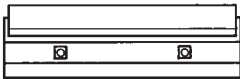

AE

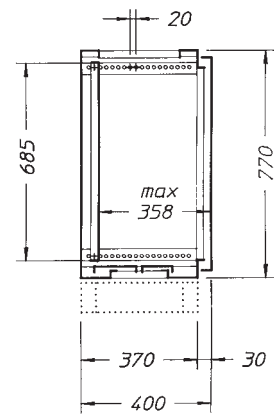
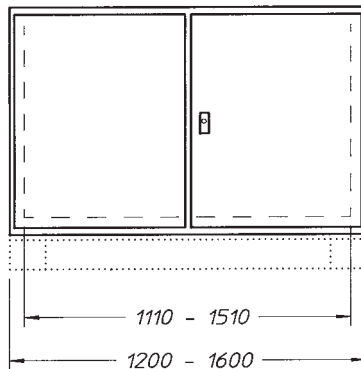
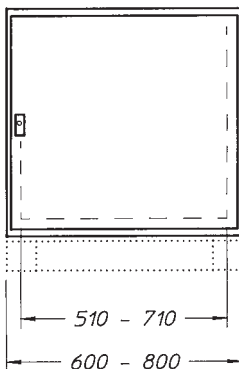

modular control desks

400mm depth dimensions

ME

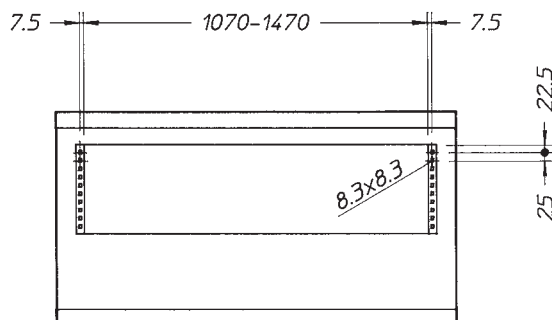
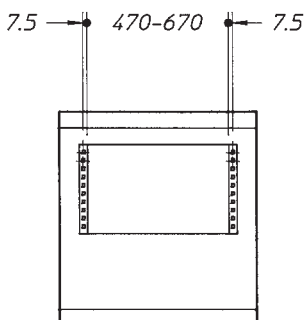
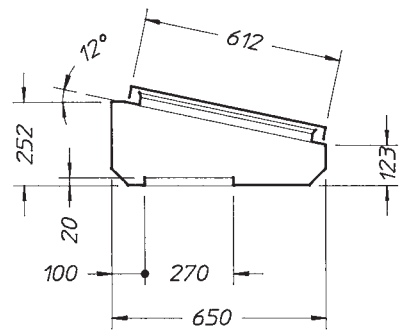
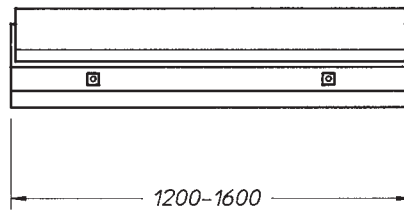
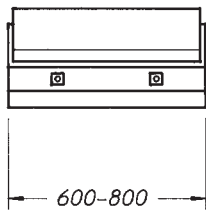
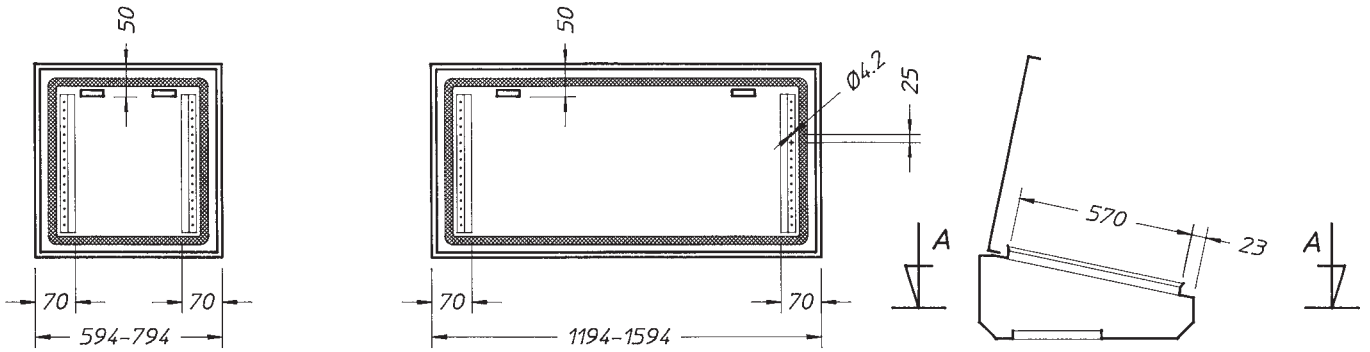

modular control desks

500mm depth dimensions

LE + PE

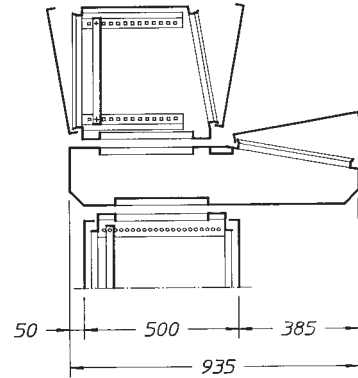
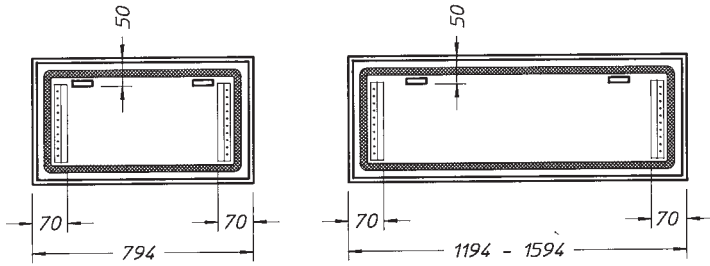

PE

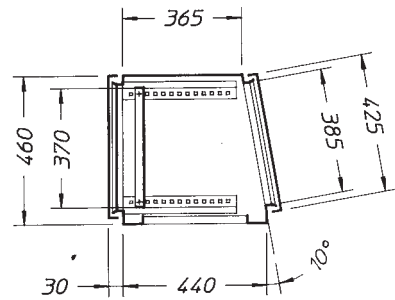
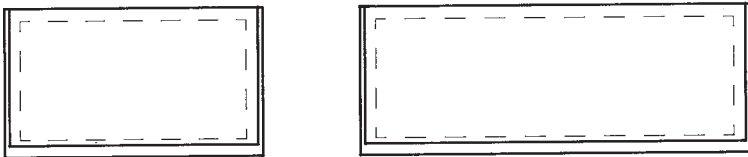

LE

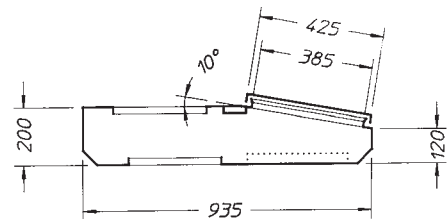

AE

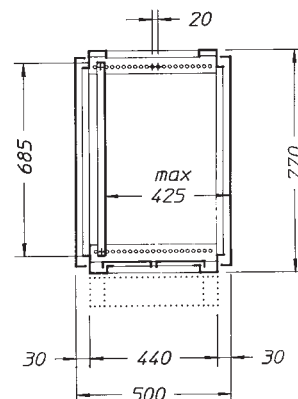
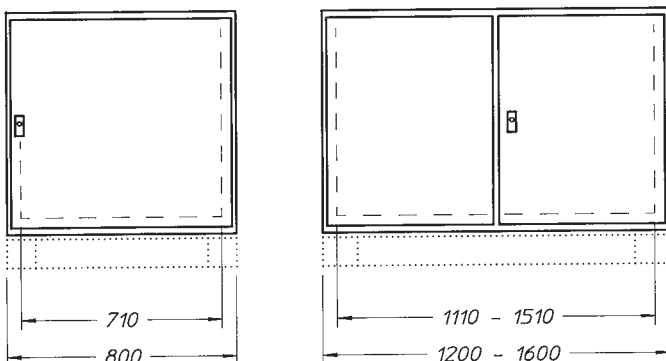

modular control desks

500mm depth dimensions

ME

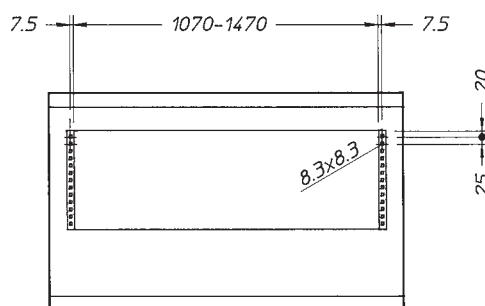
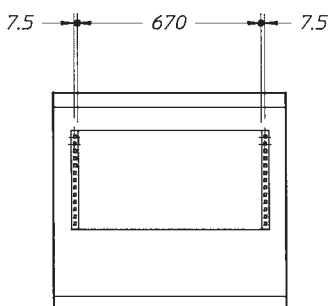
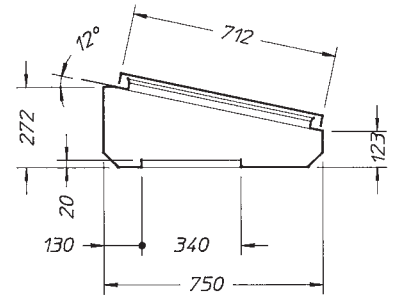
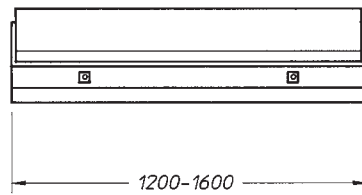
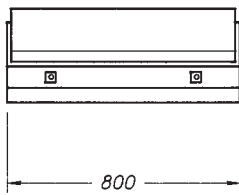
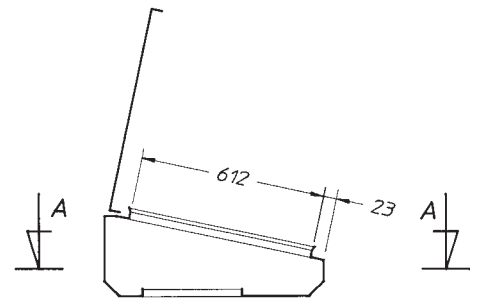
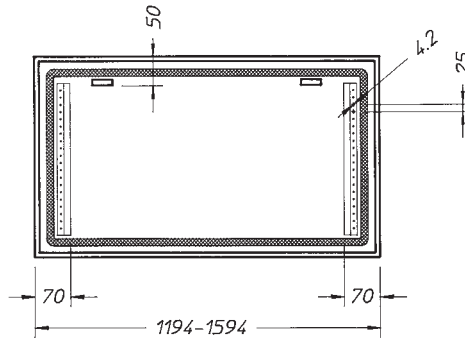
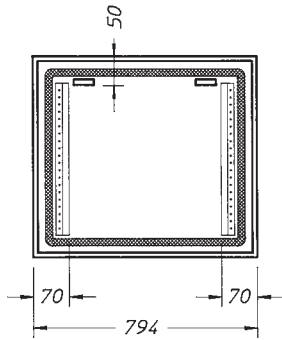

SBA monobloc control desks



characteristics

Structure manufactured from 1.5mm pressbent sheet steel.
 Mounting plate manufactured from 2.5mm sendzimir sheet steel.
 Front and rear doors manufactured from 1.5mm sheet steel with lateral stiffening cover.
 Upper panel manufactured from 1.5mm sheet steel complete with zincpassivated rails
 and gas springs to support lid.

paint finish

ETA standard epoxy polyester powder coating.
 Structure, doors, upper panel RAL 7032 textured finish.

supply includes

- SBA control desk
- doors complete with Ø 3mm double bar closing system
- mounting plate
- upper panel complete with closing system
- adjustable gland plate.

conformity and approval



protection degree

- IP 55
- type 12.

code		width
mod.	art.	
SBA 6	01	600
SBA 8	01	800
SBA 0	01	1000
SBA 2	01	1200



plinths H 100

code		dimensions	
mod.	art.	width	depth
ATZ 6	060040	600	400
	080040	800	400
	100040	1000	400
	120040	1200	400

plinths H 200

code		dimensions	
mod.	art.	width	depth
ATZ 7	060040	600	400
	080040	800	400
	100040	1000	400
	120040	1200	400

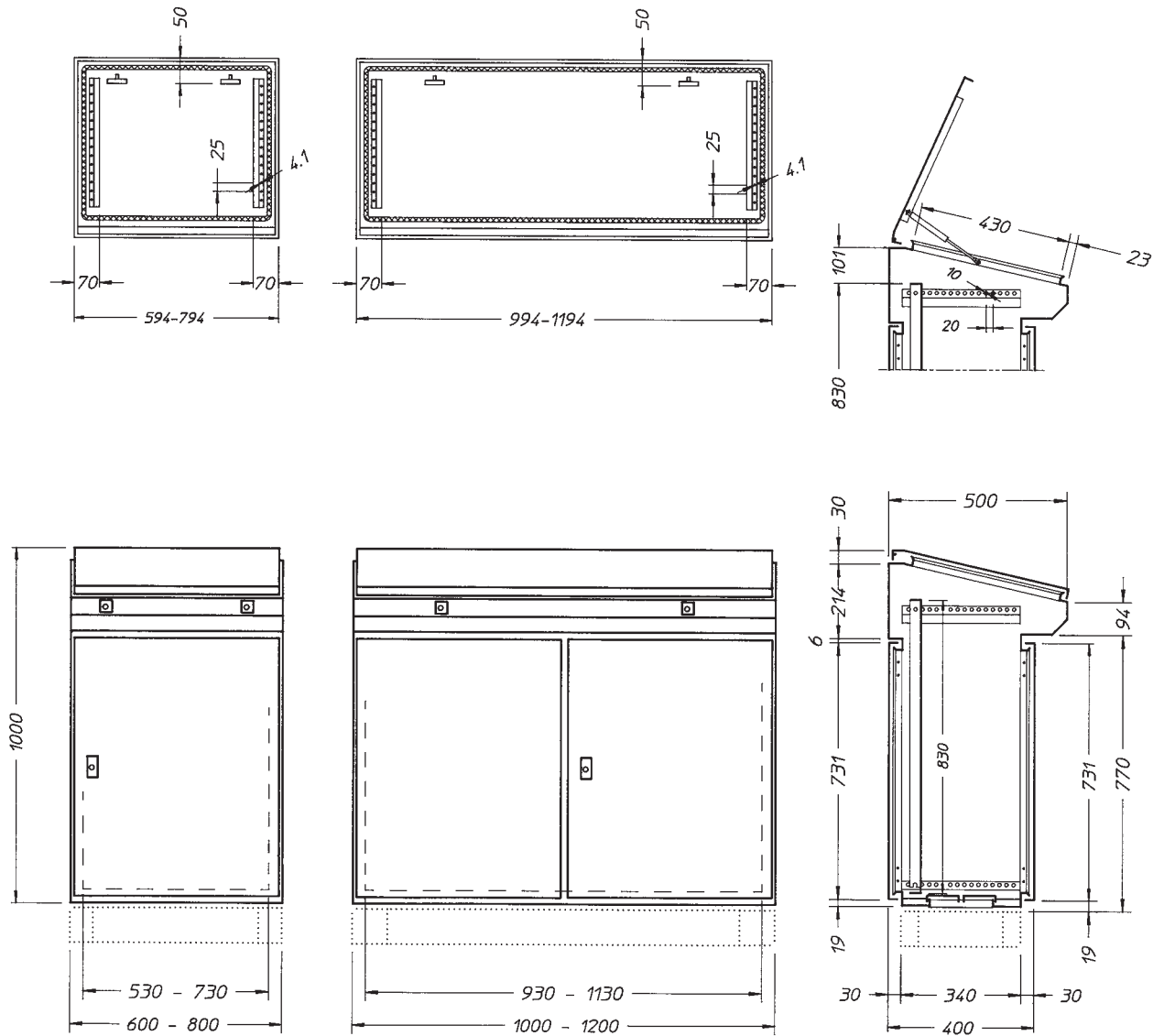

ZBA monobloc control desks



characteristics

Structure manufactured from 1.5mm pressbent sheet steel.
Mounting plate manufactured from 2.5mm sendzimir sheet steel mounted on the rear cover.
Upper cover manufactured from 1.5mm sheet steel complete with mechanical stop.
Adjustable cable entry.

paint finish

ETA standard epoxy polyester powder coating.
RAL 7032 textured finish.

supply includes

- ZBA control desk
- doors complete with Ø 3mm double bar key
- mounting plate
- upper cover complete with locking system
- adjustable gland plate.

protection degree

- IP 55.

control desks

model	width
ZBA 601	600
ZBA 801	800
ZBA 001	1000
ZBA 201	1200



plinths H 100

model	width
ZC4 105	600
ZC4 109	800
ZC4 113	1000
ZC4 117	1200

plinths H 200

model	width
ZC4 205	600
ZC4 209	800
ZC4 213	1000
ZC4 217	1200

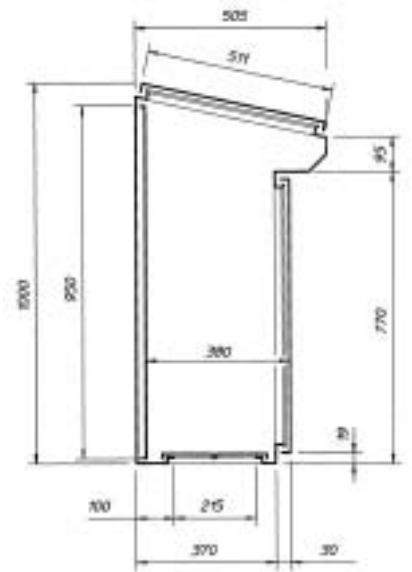
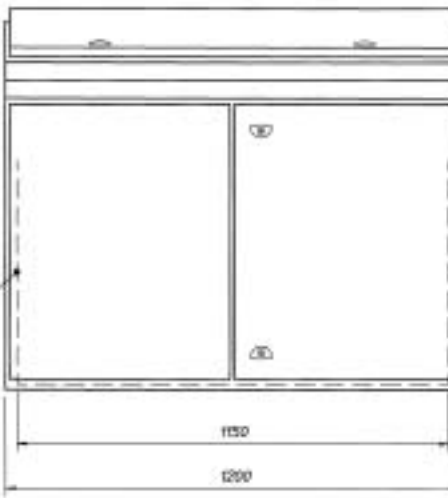
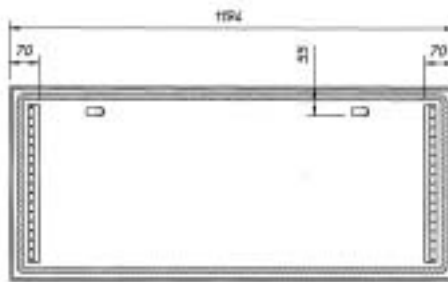
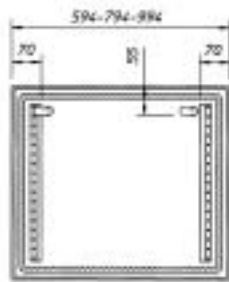

mounting plate

accessories

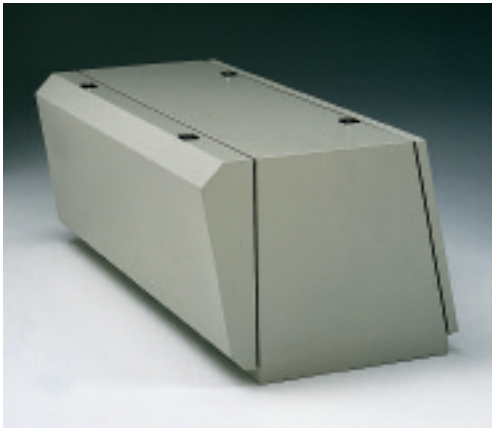

CASING PE

To be mounted on the 500mm deep PE instead of the rear panel when a greater depth is required.

characteristics

Manufactured from 1.5mm sheet steel.

paint finish

ETA standard epoxy polyester powder coating.

RAL 7032 textured finish.

supply includes

One PE casing, sealing gasket, mounting accessories.

code		PE width
mod.	art.	
PECF8	025	800
PECF1	235	1200
PECF1	645	1600

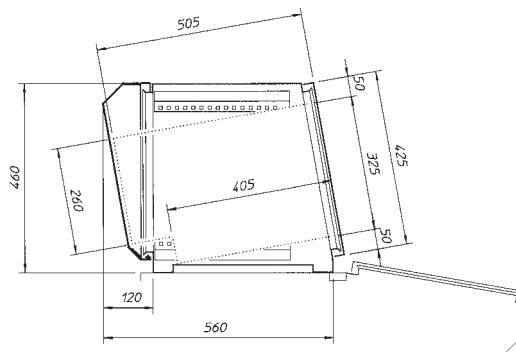

AE MOUNTING PLATE

Manufactured from 2.5mm sheet steel.

supply includes

Single piece, mounting accessories.

code		control desk width
mod.	art.	
PA 4	AE 825	800
PA 4	AE 235	1200
PA 4	AE 645	1600

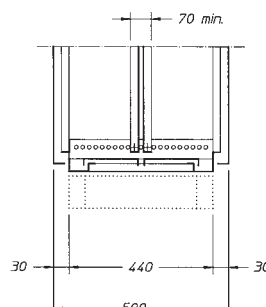

accessories

LE MOUNTING PLATE

Manufactured from 2.5mm sheet steel.

supply includes

Single piece, mounting accessories.

code		LE width
mod.	art.	
PA4-LE	015	600
PA4-LE	025	800
PA4-LE	235	1200
PA4-LE	645	1600

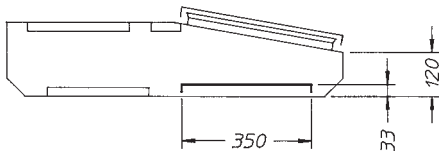

COVER TL

Manufactured from 1.5mm sheet steel.

paint finish

RAL 7032 textured finish.

supply includes

Single piece, sealing gasket, mounting accessories.

LE depth 400mm

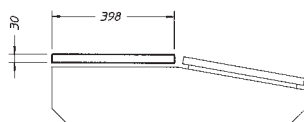

code		LE width
mod.	art.	
TL 6	01	600
TL 8	02	800
TL 1	23	1200
TL 1	64	1600

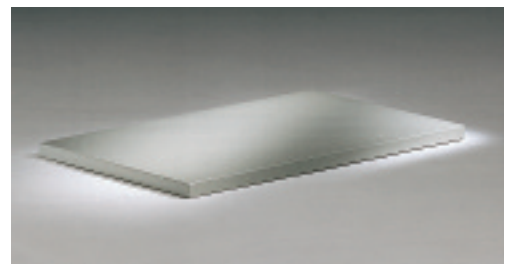

LE depth 500mm

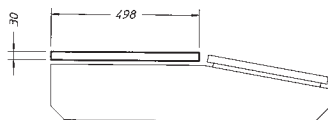

code		LE width
mod.	art.	
TL 8	025	800
TL 1	235	1200
TL 1	645	1600

HANDLE

Manufactured from aluminium alloy.

Supply includes: single piece, mounting accessories.

code		width
mod.	art.	
WA	400	600
WA	410	800
WA	430	1000
WA	440	1200
WA	450	1600

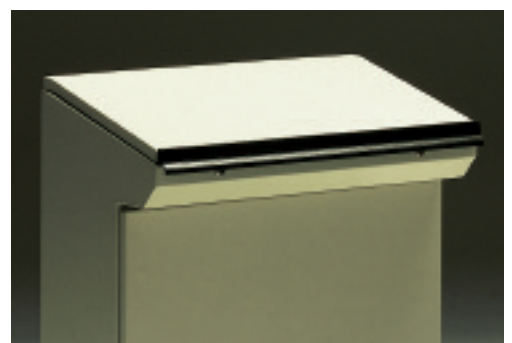

accessories

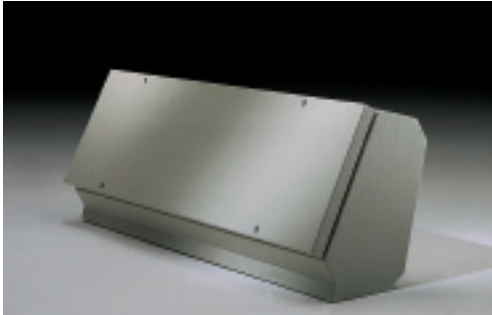

UPPER - SPA

code		width
mod.	art.	
SPA 6	01	600
SPA 8	01	800
SPA 0	01	1000
SPA 2	01	1200

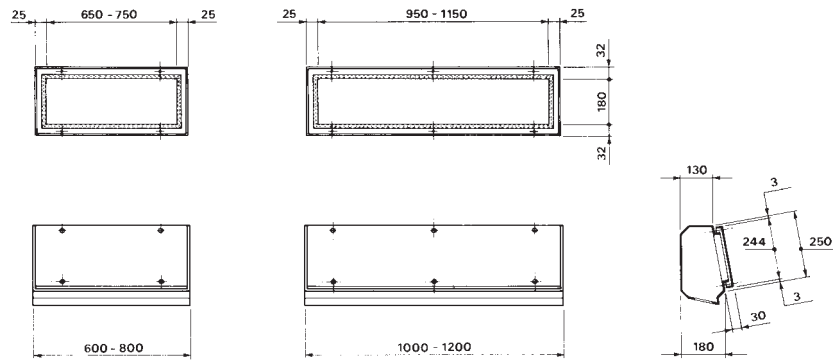
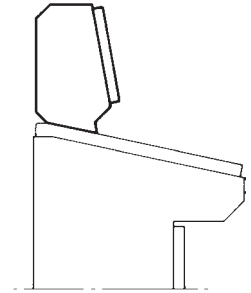

plinth for AE

code				dimensions			
mod.	art.	mod.	art.	A	B	width	depth
ZC 4	105	ZC 4	205				
ZC 4	109	ZC 4	209	800	370	800	400
ZC 4	117	ZC 4	217	1200	370	1200	400
ZC 4	121	ZC 4	221	1600	370	1600	400
ATZ 6	080050	ATZ 7	080050	800	440	800	500
ATZ 6	120050	ATZ 7	120050	1200	440	1200	500
ATZ 6	160050	ATZ 7	160050	1600	440	1600	500

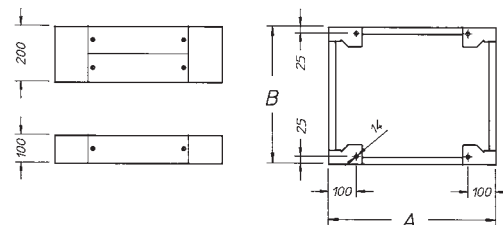

accessories

closing systems

code		ref.	description
mod.	art.		
WE	256	1	ETA insert for control desks
WE	096	2	ETA insert key
WE	261	3	insert cover <input checked="" type="checkbox"/> 6 for control desks
WE	263	4	key for insert <input checked="" type="checkbox"/> 6 "ST"
WE	266	5	insert cover <input checked="" type="checkbox"/> 7 for control desks
WE	268	6	key for insert <input checked="" type="checkbox"/> 7 "ST"
WE	271	7	insert cover <input checked="" type="checkbox"/> 6,5 for control desks
WE	273	8	key for insert <input checked="" type="checkbox"/> 6,5 "ST"
WE	276	9	insert cover <input checked="" type="checkbox"/> 8 for control desks
WE	278	10	key for insert <input checked="" type="checkbox"/> 8 "ST"
WE	240	11	ST "Fiat" key with lock cover
WE	210	12	"Fiat" key

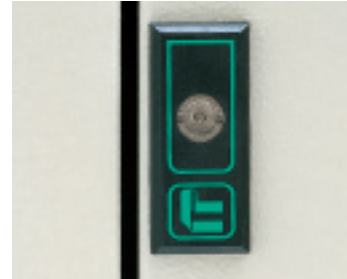

code		ref.	description
mod.	art.		
WE	010	1	rod system
WE	080	2	Fiat insert
WE	210	3	Fiat key
WE	027	4	Fiat insert cover
WE	030	5	∅ 3 ETA insert
WE	160	6	∅ 3 ETA key
WE	040	7	∅ 5 ETA insert
WE	170	8	∅ 5 ETA key
WE	050	9	insert <input checked="" type="checkbox"/> 7
WE	180	10	key <input checked="" type="checkbox"/> 7
WE	060	11	insert <input checked="" type="checkbox"/> 8
WE	190	12	key <input checked="" type="checkbox"/> 8
WE	070	13	insert <input checked="" type="checkbox"/> 7
WE	200	14	key <input checked="" type="checkbox"/> 7
WE	020	15	ETA lock cover

