

Energy Management Compact Power Transducer Type CPT-DIN "Advanced version"

CARLO GAVAZZI



- One digital output and RS485 communication port (2 wires only)
- 16 freely configurable alarms with OR/AND logic linkable to up to 2 digital outputs
- RS422/485/RS232 communication port (MODBUS-RTU), iFIX SCADA compatibility

- Class 1 (kWh), Class 2 (kvarh)
- Accuracy ± 0.5 F.S. (current/voltage)
- Compact power transducer
- Instantaneous variables data format: 4 DGT
- Energies data format: 8+1 DGT
- System variables and phase measurements: V_{LL} , V_{LN} , A , A_{max} , A_n , A_{dmd} , $A_{dmd\ max}$, VA , VA_{dmd} , $VA_{dmd\ max}$, W , W_{dmd} , $W_{dmd\ max}$, $W_{L1-W_{L2-W_{L3\ max}}$, var , PF , $PF_{L1-PF_{L2-PF_{L3\ min}}$, Hz , ASY
- Four quadrant power measurement
- Energy measurements: total and partial kWh and kvarh (according to EN62053-21 and EN62053-23)
- Hour counter (5+2 DGT)
- TRMS meas. of distorted sine waves (voltages/currents)
- Universal power supply: 90 to 260 VAC/DC, 18 to 60 VAC/DC
- Dimensions: 45x83.5x98.5mm
- Voltage asymmetry, phase sequence, phase loss control
- Up to 3 analogue outputs (20mA or 10VDC)
- 2 digital outputs

Product Description

3-phase compact power transducer. Particularly recommended for the measurement of the main electrical variables also on board of machines.
Housing for DIN-rail mount-

ing, with up to 3 analogue outputs, or RS485 communication port or alarm outputs or "Dupline" bus. Parameters programmable by means of CptASoft.

How to order

CPT-DIN AV5 3 H A3 AX

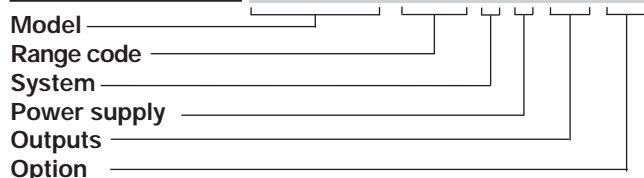

How to order

CptASoft-kit

CptASoft: software to program the working parameters of the transducer and to read the energies and the instantaneous variables. The kit includes the communication cable.

Type Selection

Range codes	System	Outputs	Options
AV5: 400/690 $V_{L-L}/1/5(6)AAC$ V_{L-N} : 185 V to 460 V V_{L-L} : 320 V to 800 V AV6: 120/208 $V_{L-L}/1/5(6)AAC$ V_{L-N} : 45 V to 145 V V_{L-L} : 78 V to 250 V Phase current: 0.01A to 6A Neutral current: 0.05A to 6A	3 : 1-2-3-phase, balanced/unbalanced load, with or without neutral 1 : 1-3-phase, balanced load (*) (*) Note: the 3-phase balanced load measurement requires the connection of the neutral according to fig. 15 and 16 in the final part of this document.	R2: 2-relay outputs O2: 2-open collector outputs RS: 1-reed relay output + RS485 port (2-wire) A1: 1-analogue output: 0/4 to 20mA DC A3: 3-analogue outputs: 0/4 to 20mA DC V1: 1-analogue output: 0 to 10V DC V3: 3-analogue outputs: 0 to 10V DC S1: RS485/RS422 port S2: RS232 port DB: Dupline bus	AX: advanced functions Power supply L: 18 to 60 VAC/VDC H: 90 to 260 VAC/VDC

Input specifications

Rated inputs	System type: 3	Neutral current	
Current	3 (internal current transformers)	Phase-phase voltage	$\pm(2\%RDG+3DGT)$
Voltage	4	Phase-neutral voltage	$\pm(0.5\%RDG+2DGT)$
Current	System type: 1	Active and Apparent power, Reactive power	$\pm(1.5\%RDG+3DGT)$
Voltage	1 (internal CT)	Range accuracy: 0.05In to Imax	$\pm(3\%RDG+3DGT)$
Accuracy (RS485) (@25°C $\pm 5^\circ C$, R.H. $\leq 60\%$)	2	Current	$\pm(0.5\%RDG+2DGT)$
Range accuracy: 0.02In to 0.05In	Imax: 6A, Vmax: 400 V_{LN} (690 V_{LL}), In: 5A, Vn: 230 V_{LN} (400 V_{LL})	Neutral current	$\pm(1\%RDG+3DGT)$
Current	CT: 1, VT (PT): 1	Phase-phase voltage	$\pm(0.5\%RDG+2DGT)$
	$\pm(0.5\%FS)$ or $\pm(1\%RDG+2DGT)$	Phase-neutral voltage	$\pm(0.5\%RDG+2DGT)$
		Active and Apparent power,	$\pm(1\%RDG+3DGT)$

Specifications are subject to change without notice CPT-DINADS110706



Input specifications (cont.)

Reactive power	±(2%RDG+3DGT)	Hourcounter	5+2 DGT, max indication 9 999 9.99
Active energy	Class 2 according to EN62053-21 (I start up: 10mA)	Measurements	Current, voltage, power, power factor, frequency TRMS measurement of distorted waves.
Reactive energy	Class 3 according to EN62053-23 (I start up: 10mA)		
Frequency	±0.1Hz (48 to 62Hz)	Type	Direct
Additional errors	≤0.3% FS, 60% to 90% RH	Coupling type	< 3, max 10A peak
		Humidity	
Frequency	≤0.3% FS (45 to 48Hz and 62 to 65Hz)	Crest factor	
Temperature drift	≤ 200ppm/°C	Input impedance	1.6 MΩ ±5%
Sampling rate	1600 samples/s @ 50Hz 1900 samples/s @ 60Hz	400/690V _{L-L} (AV5)	1.6 MΩ ±5%
		120/208V _{L-L} (AV6)	≤ 0.01Ω
Measurement refresh time	200ms	Current	
Measurement format	(serial communication)	Frequency	45 to 65 Hz
		Instantaneous variables	
Energies	4 DGT, max indication 9999 8+1 DGT, max indication 999 999 99.9	Overload protection	(max values)
		Continuos voltage/current	AV5: 460V _{LN} /800V _{LL} /6A AV6: 145V _{LN} /250V _{LL} /6A
		For 500ms: voltage/current	AV5: 800V _{LN} /1380V _{LL} /36A AV6: 240V _{LN} /416V _{LL} /36A

Output Specifications

Analogue Outputs	Number of outputs	Up to 3	Set-point adjustment	From 0 to 100% of the retransmitted scale	
	Accuracy (@ 25°C ±5°C, R.H. ≤60%)	±0.3% FS	Hysteresis	from 0 to full scale	
	Range	0 to 20mA or 0 to 10 VDC	On-time delay	0 to 255s	
	Scaling factor:	Programmable within the whole range of retransmission; it allows the retransmission management of all values from: 0 and 20 mA, 0 and 10VDC	Output status	Selectable; normally de-energized and normally energized	
	Response time	≤ 400 ms typical (filter excluded)	Min. response time	≤400ms, filters excluded and with alarm delay: "0 s"	
	Ripple	≤ 1%, according to IEC 60688-1, EN 60688-1	Note	The 2 digital outputs can also work as one pulse output and one alarm output.	
	Total temperature drift	≤ 500 ppm/°C			
	Load: 20 mADC	≤ 350 Ω	Static outputs		
	Insulation	By means of optocouplers, See table "Insulation between inputs and outputs"	Purpose	For alarm outputs or for pulse outputs	
			Signal	V _{ON} 1.2 VDC/ max. 100 mA V _{OFF} 30 VDC max.	
		Insulation	By means of optocouplers, See table "Insulation between inputs and outputs"		
Digital outputs	Pulse	Up to 2	Relay outputs	Purpose	For alarm outputs or for pulse outputs
	Type	Outputs connectable to the total energy meters (Wh/varh)	AC 1-5A @ 250VAC	DC 12-5A @ 24VDC	
	Pulse duration	≥ 100ms <120msec (ON), ≥ 120ms (OFF) according to EN62053-31	AC 15-1.5A @ 250VAC	DC 13-1.5A @ 24VDC	See table "Insulation between inputs and outputs"
Alarm			Reed relay output	Purpose	For alarm output or for pulse output
Number of outputs	up to 2, independent		Type	Reed relay, SPST type NO	Max 200VDC, peak AC resistive
Alarm modes	Up alarm, down alarm, in window alarm, out window alarm.		Switching voltage	Max 0.5ADC, peak AC resistive	Max 2ADC, peak AC resistive
	Start-up deactivation function at power-on for all kinds of alarm. All of them connectable to all variables (see the table "List of the variables that can be connected to")		Switching current	300x10 ⁶ operations (1V/10mA)	See table "Insulation between inputs and outputs"
			Carry current		
			Mechanical life		
			Insulation		



Output Specifications (cont.)

RS422/RS485	(on request) Multidrop bidirectional (static and dynamic variables) 2 or 4 wires, max. distance 1200m, termination directly on the instrument	Connections	RS232 Type Connections Address Protocol Baud-rate	Halfduplex communication Point to point connection 3-wire, max. distance 15m 1 to 255 selectable via software MODBUS/JBUS (RTU) 4800, 9600, 19200, 38400 bits/s other characteristics like R422/RS485 port
		Addresses		
Protocol Data (bidirectional) Dynamic (reading only)	From 1 to 255, selectable via software MODBUS/JBUS (RTU)	System and phase variables: see table "List of variables..." All the configuration parameters.	Dupline	Full Dupline compatibility Programmable using CptASoft kWh, kvarh + 8 variables chosen among the available ones. By means of optocouplers. See table "Insulation between inputs and outputs"
			Static (writing only)	
Data format	1 start bit, 8 data bit, no parity, 1 stop bit		Bus Address Variables	
Baud-rate	4800, 9600, 19200, 38400 bits/s		Insulation	
Insulation	By means of optocouplers, See table "Insulation between inputs and outputs"			

RS232 Configuration Bus

Connections	RJ12 (3-wire) for special cable	Insulation	By means of optocouplers, See table "Insulation between inputs and outputs"
Baud-rate	4800 bits/s		
Data format	1 start bit, 8 data bit, no parity, 1 stop bit		

CptASoft software: parameter programming and data reading

CptASoft	Multi language software to program the working parameters of the transducer and to read the energies and the instantaneous variables. Compatibility with Windows 95/98/98SE/2000/XP.		Filtering parameters Alarm variables Alarm set-points and relevant parameters Variables to be connected to the analogue outputs Scaling of analogue outputs Energies to be connected to the pulse outputs Parameters related to the pulse outputs Reset function: max/min values, energies, dmd
Working mode	Two different working modes can be selected: - management of a local RS485 network; - management of the communication from single instrument to PC (RS232);		
Programming parameters	System selection: 1-2-3 phases CT/VT ratios	Data access	By means of RS232 serial port, RS485 serial port or RS232 configuration port (RJ12)

Software functions

System selection	3-phase (3-wire, 4-wire) 3-phase ARON 2-phase (3-wire)	Transformer ratio	CT VT (PT)	1 to 60 000 1.0 to 6 000.0
System 3, unbalanced	1-phase (2-wire) 3-phase (3-wire, 4-wire)	Filter	Operating range	0 to 100% of the retransmitted scale
System 3, balanced	3-phase (3-wire) "1CT+1VT" 3-phase (3-wire) "1CT+3VT"	Filtering coefficient	Filter action	1 to 32 Measurements, alarms, serial output (fundamental variables: V, A, W and their derived ones).
System 1, balanced	3-phase (4-wire) "1CT+1VT" 3-phase (4-wire), phase to neutral voltage measurement 1-phase (2-wire)			



Software functions (cont.)

Alarms	<p>“OR” or “AND” or “OR+AND” functions (see “Alarm parameter and logic” page). The user can freely program up to 16 total alarms. (out1+out2). The alarms can be connected to any variables available in the table “List of the variables that can be connected to”</p>	<p>- W dmd max, VA dmd max, A₁ max, A₂ max, A₃ max, W_{L1} max, W_{L2} max, W_{L3} max, W sys max, A₁ dmd max, A₂ dmd max, A₃ dmd max, VA sys dmd max, W sys dmd max, PF₁ min, PF₂ min, PF₃ min - all the counters: total kWh, partial kWh, total kvarh, partial kvarh, hour counters - reset of all the above mentioned variables in a single command</p>
Reset	<p>The following resets are available by means of the configuration software: - all the maximum/min values:</p>	

Power Supply Specifications

AC/DC voltage	90 to 260VAC/DC 18 to 60VAC/DC	Power consumption	AC: 2.5 VA DC: 2W
----------------------	-----------------------------------	--------------------------	----------------------

General Specifications

Front LED's	Green	<p>4kVAC_{RMS} between power supply and RS485/RS232/programming port (RJ12)</p>
Power on		
Diagnostics		Dielectric strength
RS485/RS422/RS232	TX data (Green) RX data (Red)	EMC
Dupline bus	TX data (Green) RX data (Red)	Emissions
Alarm outputs	1st output activation (Green) 2nd output activation (Red)	Immunity
Pulse outputs	1st output activation (Green) 2nd output activation (Red)	Pulse voltage (1.2/50µs)
Analogue outputs	Output signal within the programmed scale (Green) Output signal exceeding 110% of full scale (Red)	Safety standards
Operating temperature	0° to +50°C (32° to 122°F) (RH < 90% non condensing)	Mesurement standards
Storage temperature	-10° to +60°C (14° to 140°F) (RH < 90% non condensing)	Approvals
Overvoltage category	Cat. III (IEC 60664, EN60664)	Connections 5(6) A
Insulation (for 1 minute)	4kVAC _{RMS} between measuring inputs and power supply. 4kVAC/DC @ I _z 3mA between measuring inputs and RS485/RS232/programming port (RJ12)	Weight
		Screw-type
		Max cable cross sect. area
		2.5 mm ²
		Housing
		Dimensions (WxHxD)
		45 x 83.5 x 98.5 mm
		Material
		ABS
		self-extinguishing: UL 94 V-0
		Mounting
		DIN-rail
		Protection degree
		IP20

List of the variables that can be connected to:

- RS485/RS422/RS232 communication port
- Analogue outputs ("max" variables, "energies" and "hour counter" excluded)
- Alarm outputs ("max" variables, energies and "hour counter" excluded)
- Pulse outputs (only "energies")
- Dupline bus (only "total energies" + up to 8 selectable variables)

No	Variable	1-phase system	2-phase system	3-ph. 4-wire balanced sys.	3-ph. 4-wire unbal. sys.	3-ph. 3-wire bal. sys.	3-ph. 3-wire unbal. sys.	Notes
1	V L1	x	x	x	x	o	o	
2	V L2	o	x	x	x	o	o	
3	V L3	o	o	x	x	o	o	
4	V L-N sys	o	x	x	x	o	o	Sys = system
5	V L1-2	o	x	x	x	x	x	
6	V L2-3	o	x	x	x	x	x	
7	V L3-1	o	o	x	x	x	x	
8	V L-L sys	o	x	x	x	x	x	Sys = system
9	A L1	x	x	x	x	x	x	#
10	A L2	o	x	x	x	x	x	#
11	A L3	o	o	x	x	x	x	#
12	Amax/ Admd max	x	x	x	x	x	x	◆ Highest value among the 3-ph
13	An	o	x	x	x	x	x	
14	W L1	x	x	x	x	o	o	◆
15	W L2	o	x	x	x	o	o	◆
16	W L3	o	o	x	x	o	o	◆
17	W sys	o	x	x	x	x	x	Sys = system
18	var L1	x	x	x	x	o	o	
19	var L2	o	x	x	x	o	o	
20	var L3	o	o	x	x	o	o	
21	var sys	o	x	x	x	x	x	Sys = system
22	VA L1	x	x	x	x	o	o	
23	VA L2	o	x	x	x	o	o	
24	VA L3	o	o	x	x	o	o	
25	VA sys	o	x	x	x	x	x	Sys = system
26	PF L1	x	x	x	x	o	o	★
27	PF L2	o	x	x	x	o	o	★
28	PF L3	o	o	x	x	o	o	★
29	PF sys	o	x	x	x	x	x	Sys = system
30	Hz	x	x	x	x	x	x	
31	Phase seq.	o	o	x	x	x	x	
32	ASY L-N	o	x	x	x	x	x	
33	ASY L-L	o	x	x	x	x	x	
34	VA sys dmd	x	x	x	x	x	x	Sys = system ◆
35	W sys dmd	x	x	x	x	x	x	Sys = system ◆
36	A L1 dmd	x	x	x	x	x	x	dmd = (*)
37	A L2 dmd	o	x	x	x	x	x	dmd = (*)
38	A L3 dmd	o	o	x	x	x	x	dmd = (*)
39	VA L1 dmd	x	x	x	x	x	x	dmd = (*)
40	VA L2 dmd	o	x	x	x	x	x	dmd = (*)
41	VA L3 dmd	o	o	x	x	x	x	dmd = (*)
42	W L1 dmd	x	x	x	x	x	x	# dmd = (*)
43	W L2 dmd	o	x	x	x	x	x	# dmd = (*)
44	W L3 dmd	o	o	x	x	x	x	# dmd = (*)
45	kWh	x	x	x	x	x	x	Total and partial
46	kvarh	x	x	x	x	x	x	Total and partial
47	hours	x	x	x	x	x	x	

(x) = available (o) = not available

- ◆ These variables are available also for the MAX values stored in the EEPROM when the instrument switches off.
 ★ These variables are available also for the MIN values stored in the EEPROM when the instrument switches off.
 (*) dmd value integrated in a programmed time interval.
 (#) The variables are available also for the max values. When the instrument switches off, the values are not stored.

Specifications are subject to change without notice CPT-DINADS110706



Alarm parameters and logic



- Block enable.
- Controlled variable (VLN, ...).
- Alarm type (up, down, in window alarm, out window alarm).
- Activation function.
- ON set-point.
- OFF set-point.
- ON delay.
- Logical function (AND, OR).
- Digital output (1, 2).

} **A, B, C... up to 16**
parameter control blocks.

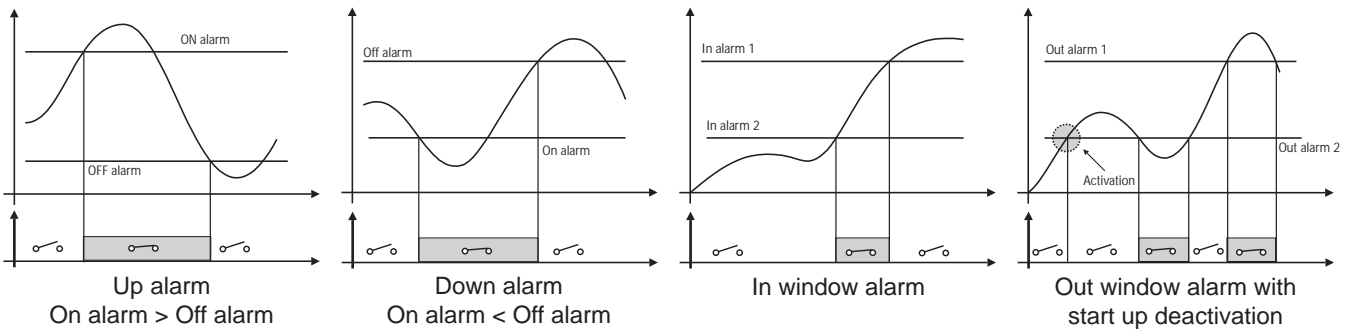

Note: any alarm working mode can be linked to the "start up deactivation" function which disables only the first alarm after power on of the transducer.

AND/OR logical alarm examples:

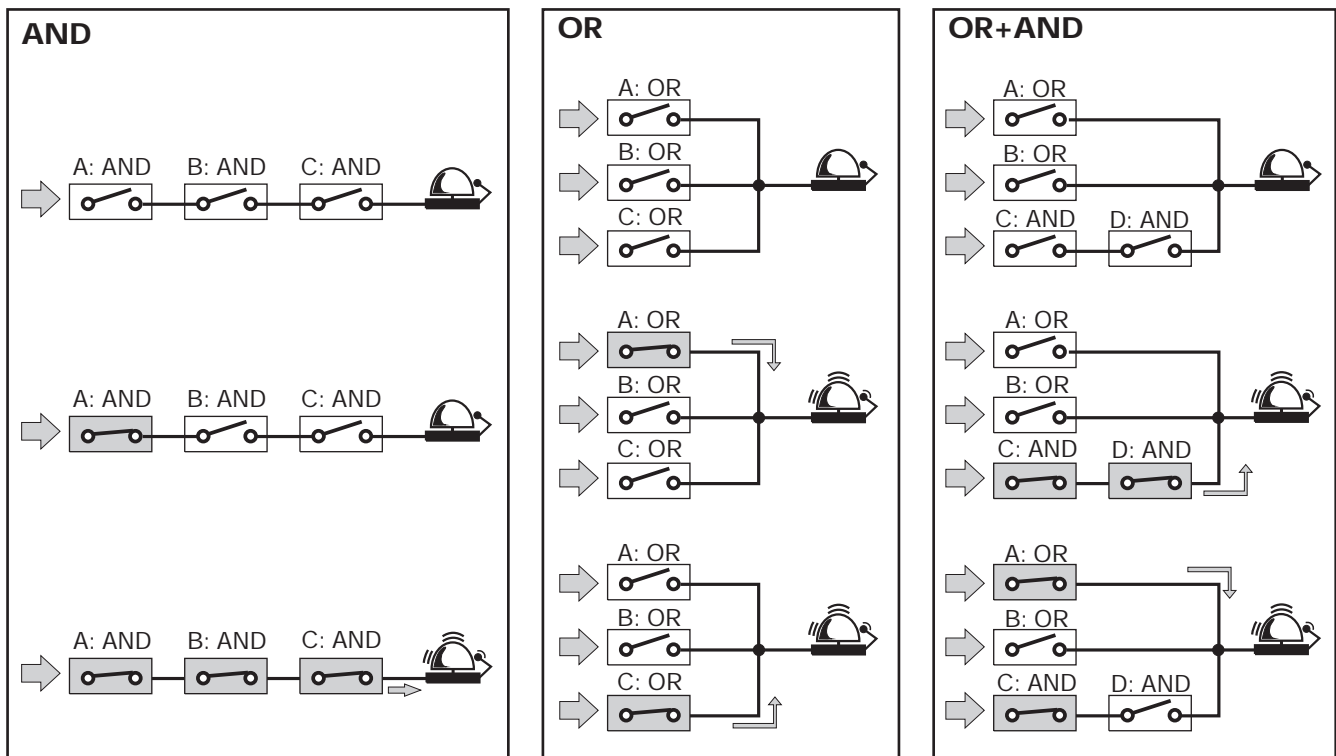

Function Description

Input and output scaling capability. Working of the analogue outputs (y) versus input variables (x)

Figure A

The sign of measured quantity and output quantity remains the same. The output quantity is proportional to the measured quantity.

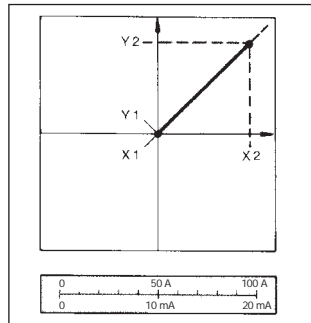

Figure C

The sign of measured quantity and output quantity remains the same. With the measured quantity being zero, the output quantity already has the value $Y_1 = 0.2 Y_2$. Live zero output.

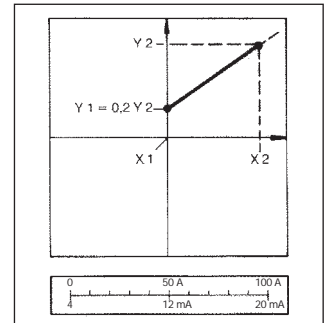

Figure B

The sign of measured quantity and output quantity remains the same. On the range $X_0...X_1$, the output quantity is zero. The range $X_1...X_2$ is delineated on the entire output range $Y_0 = Y_1...Y_2$ and thus presented in strongly expanded form.

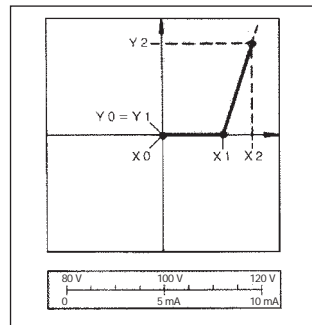
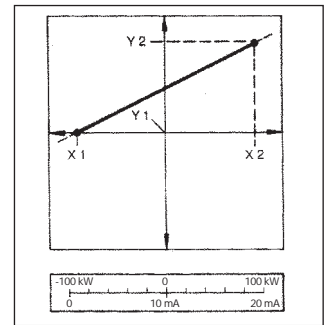

Figure D

The sign of the measured quantity changes but that of the output quantity remains the same. The output quantity steadily increases from value X_1 to value X_2 of the measured quantity.



Insulation between inputs and outputs

	Measuring Input	Relay Output	Open collector output	Reed relay	Dupline output	Analogue Output	RS232/RS485	RS232 (RJ12)	90-260VAC/DC Power supply	18-60VCA/CC Power supply
Measuring input	-	4kV	2,5kV @ $I \geq 3mA$	2,5kV	2,5kV	2,5kV @ $I \geq 3mA$	2,5kV @ $I \geq 3mA$	2,5kV @ $I \geq 3mA$	4kV	4kV
Relay output	4kV	-	-	-	-	-	-	4kV	4kV	4kV
Open collector output	2,5kV @ $I \geq 3mA$	-	-	-	-	-	-	4kV	4kV	4kV
Reed relay	2,5kV	-	-	-	-	-	100V _{RMS}	4kV	4kV	4kV
Dupline output	2,5kV	-	-	-	-	-	-	2,5kV	2,5kV	2,5kV
Analogue output	2,5kV @ $I \geq 3mA$	-	-	-	-	-	-	4kV	4kV	4kV
RS232/RS485	2,5kV @ $I \geq 3mA$	-	-	100V _{RMS}	-	-	-	4kV	4kV	4kV
RS232 (RJ12)	2,5kV @ $I \geq 3mA$	4kV	4kV	4kV	2,5kV	4kV	4kV	-	4kV	4kV
90-260 VAC/DC	4kV	4kV	4kV	4kV	2,5kV	4kV	4kV	4kV	-	-
18-60 VAC/DC	4kV	4kV	4kV	4kV	2,5kV	4kV	4kV	4kV	-	-

NOTE: in case of fault of first insulation the current from the measuring input to the ground is lower than 2mA.



Waveform of the signals that can be measured

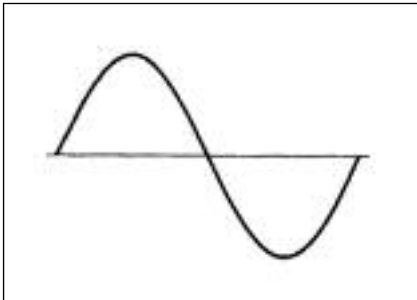

Figure A
Sine wave, undistorted
 Fundamental content 100%
 Harmonic content 0%
 $A_{rms} = 1.1107 | \bar{A} |$

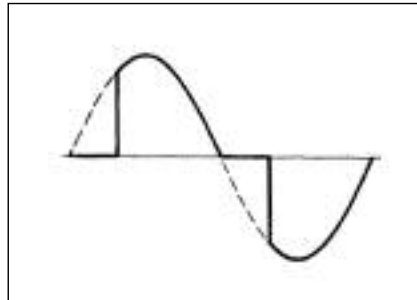

Figure B
Sine wave, indented
 Fundamental content 10...100%
 Harmonic content 0...90%
 Frequency spectrum: 3rd to 16th harmonic
 Additional error: <1% FS

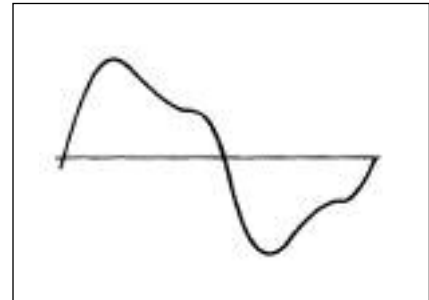
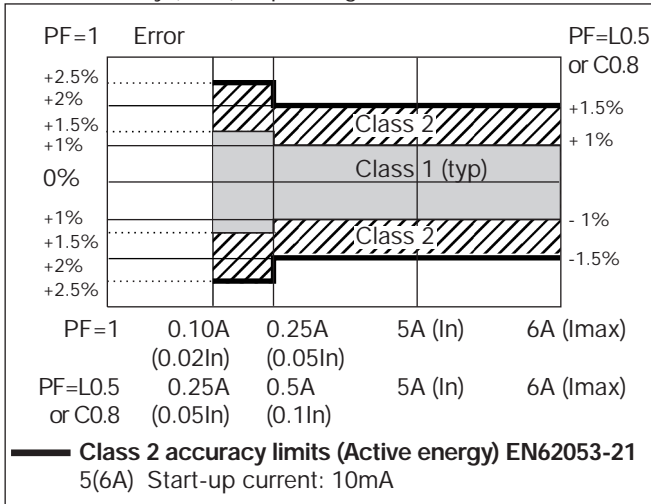

Figure C
Sine wave, distorted
 Fundamental content 70...90%
 Harmonic content 10...30%
 Frequency spectrum: 3rd to 16th harmonic
 Additional error: <0.5% FS

Accuracy

kWh, accuracy (RDG) depending on the current



kvarh, accuracy (RDG) depending on the current

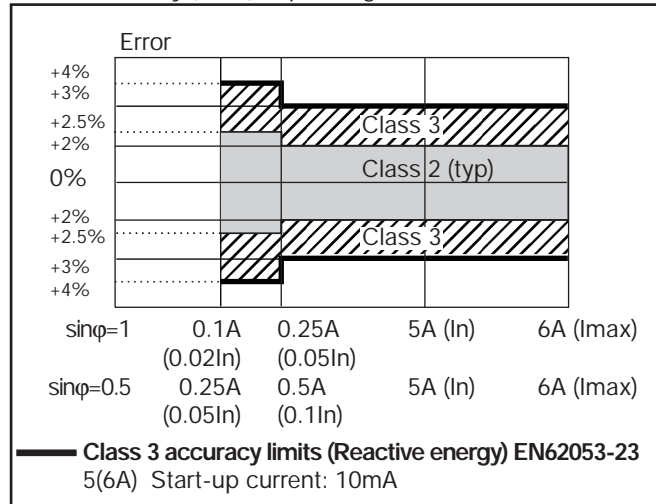

Used calculation formulas

Phase variables

Instantaneous effective voltage

$$V_{IN} = \sqrt{\frac{1}{n} \cdot \sum_1^n (V_{INi})^2}$$

Instantaneous active power

$$W_1 = \frac{1}{n} \cdot \sum_1^n (V_{INi}) \cdot (A_1)_i$$

Instantaneous power factor

$$\cos\phi_1 = \frac{W_1}{VA_1}$$

Instantaneous effective current

$$A_1 = \sqrt{\frac{1}{n} \cdot \sum_1^n (A_1)_i^2}$$

Instantaneous apparent power

$$VA_1 = V_{IN} \cdot A_1$$

Instantaneous reactive power

$$VAR_1 = \sqrt{(VA_1)^2 - (W_1)^2}$$

System variables

Equivalent three-phase voltage

$$V_{\Sigma} = \frac{V_{12} + V_{23} + V_{31}}{3}$$

Voltage asymmetry

$$ASY_{LL} = \frac{(V_{LLmax} - V_{LLmin})}{V_{LL \Sigma}}$$

$$ASY_{LN} = \frac{(V_{LNmax} - V_{LNmin})}{V_{LN \Sigma}}$$

Three-phase reactive power

$$VAR_{\Sigma} = (VAR_1 + VAR_2 + VAR_3)$$

Neutral current

$$An = \overline{A_{L1}} + \overline{A_{L2}} + \overline{A_{L3}}$$

Three-phase active power

$$W_{\Sigma} = W_1 + W_2 + W_3$$

Three-phase apparent power

$$VA_{\Sigma} = \sqrt{W_{\Sigma}^2 + VAR_{\Sigma}^2}$$

Three-phase power factor (TPF)

$$\cos\phi_{\Sigma} = \frac{W_{\Sigma}}{VA_{\Sigma}}$$

Energy metering

$$kWh_i = \int_{t_1}^{t_2} P_i(t) dt \approx \Delta t \sum_{n_1}^{n_2} P_{i,j}$$

$$kVarh_i = \int_{t_1}^{t_2} Q_i(t) dt \approx \Delta t \sum_{n_1}^{n_2} Q_{i,j}$$

Where:

i= considered phase (L1, L2 or L3)
 P= active power; Q= reactive power;
 t_1, t_2 = starting and ending time points of consumption recording; n= time unit; Δt = time interval between two successive power consumptions;
 n_1, n_2 = starting and ending discrete time points of consumption recording

Wiring diagrams "system type selection: 3"

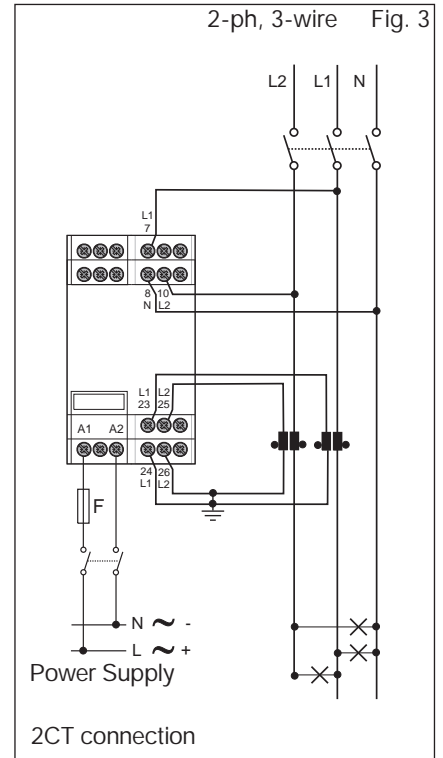
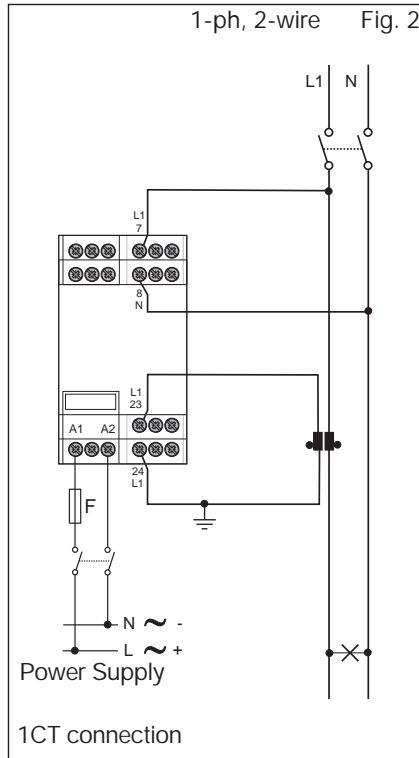
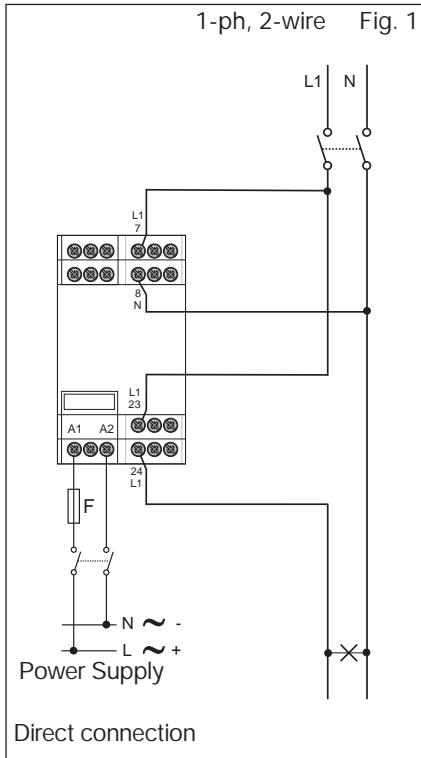

F= 630 mA T (18 to 60VAC/DC)
125 mA T (90 to 260VAC/DC)

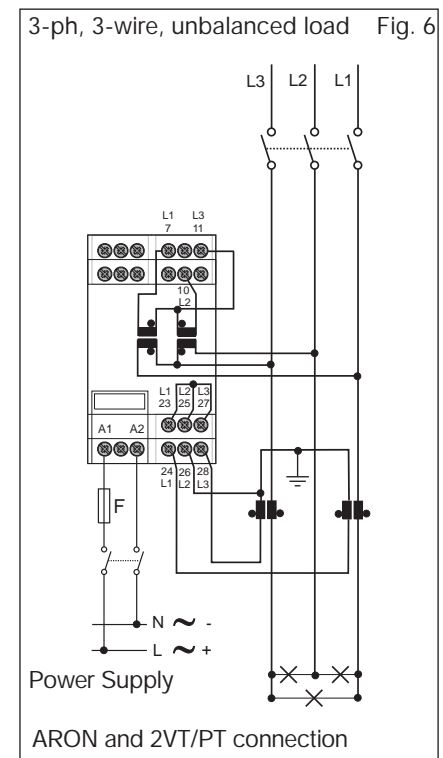
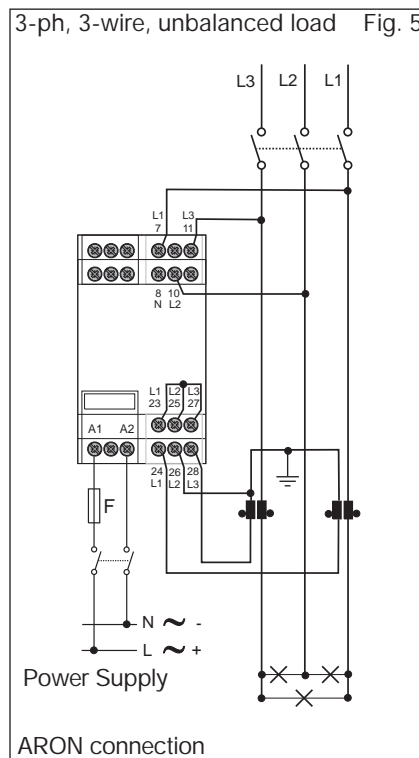
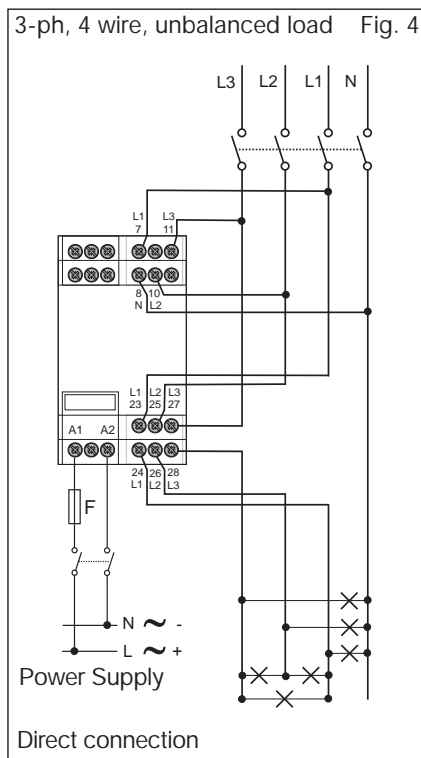

Wiring diagrams "system type selection: 3" (cont.)

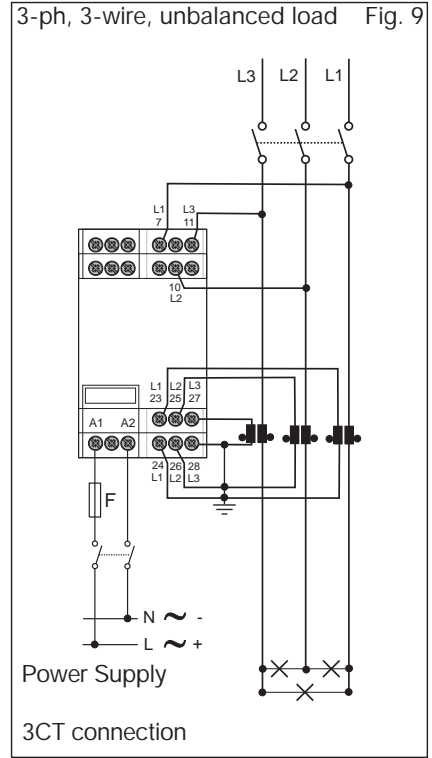
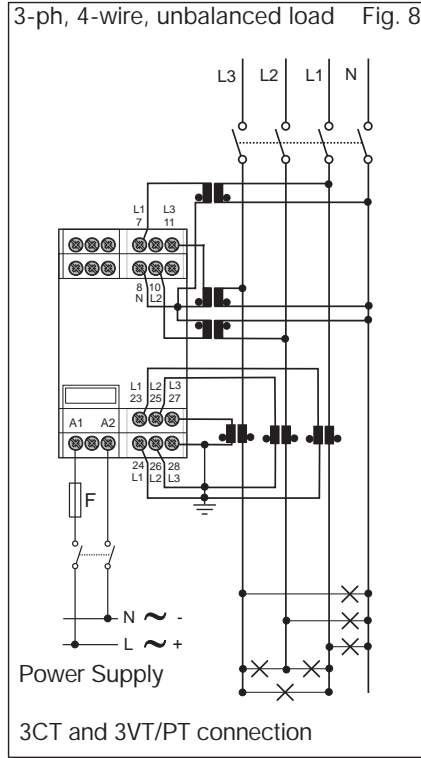
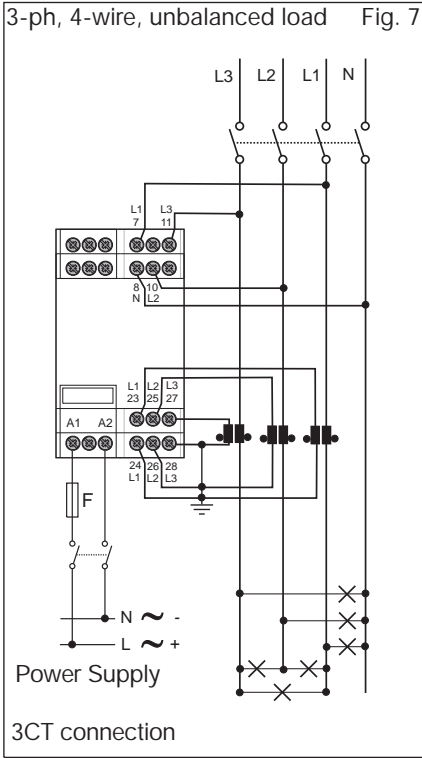

F= 630 mA T (18 to 60VAC/DC)
125 mA T (90 to 260VAC/DC)

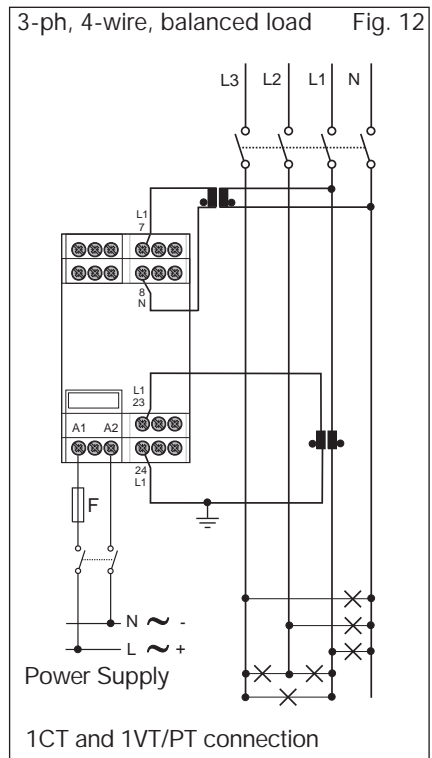
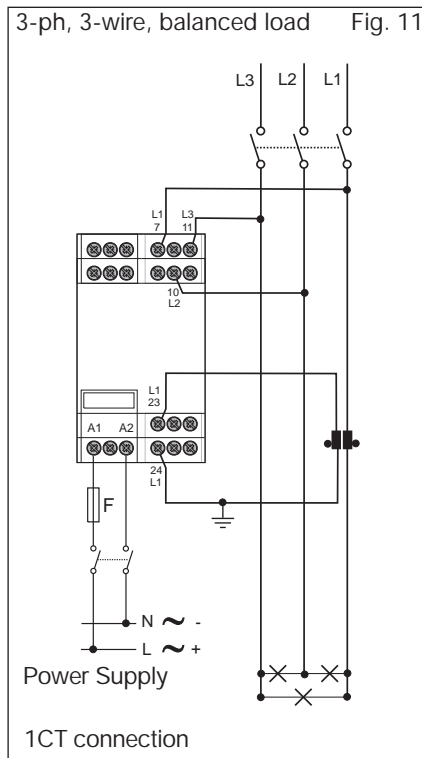
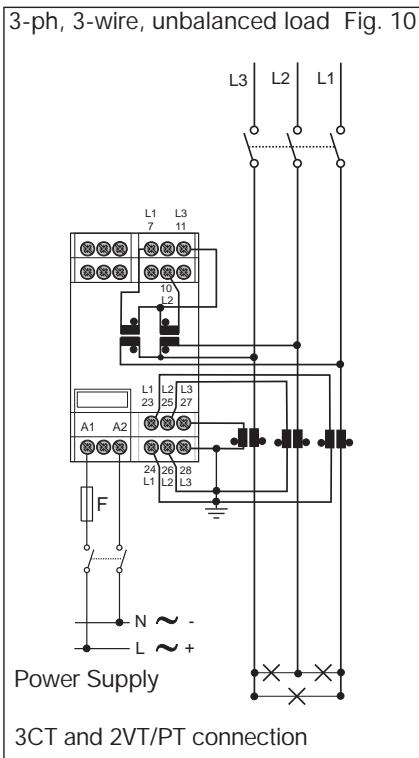

Wiring diagrams "system type selection: 1"

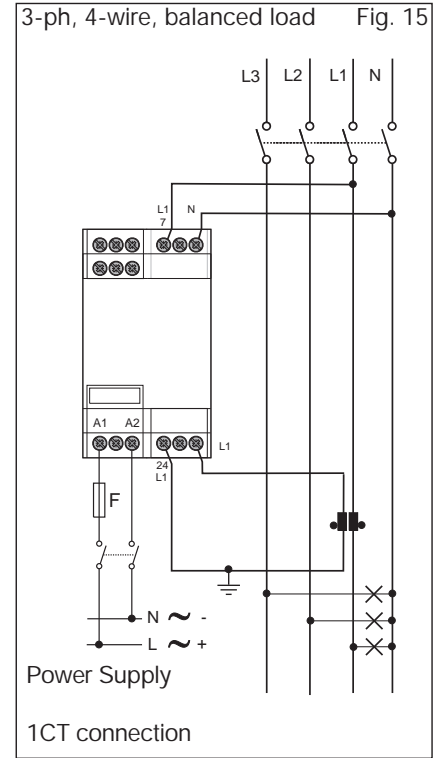
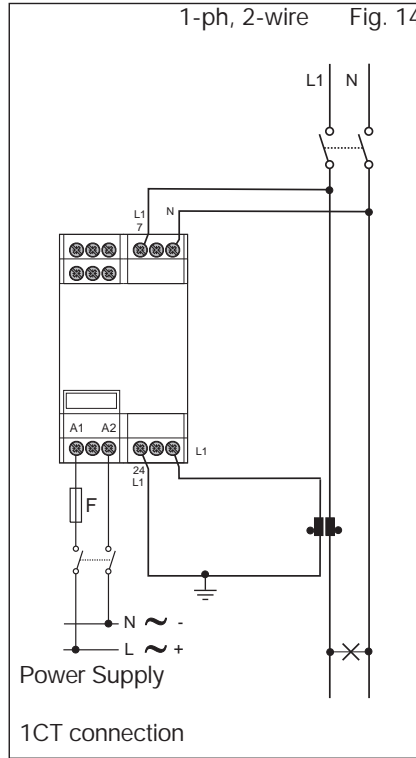
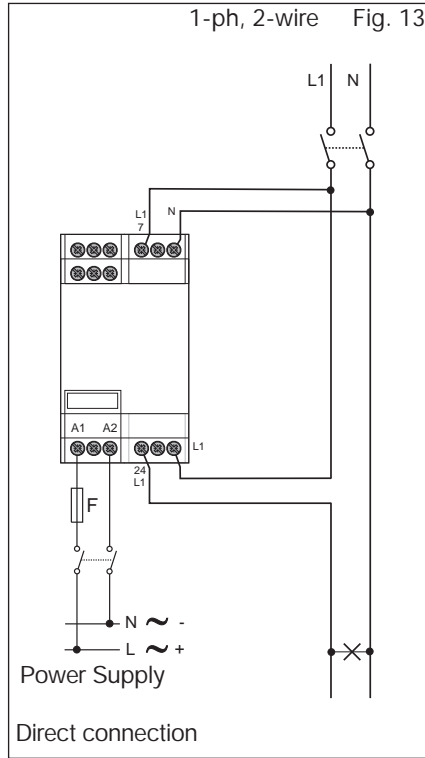

F= 630 mA T (18 to 60VAC/DC)
125 mA T (90 to 260VAC/DC)

Outputs

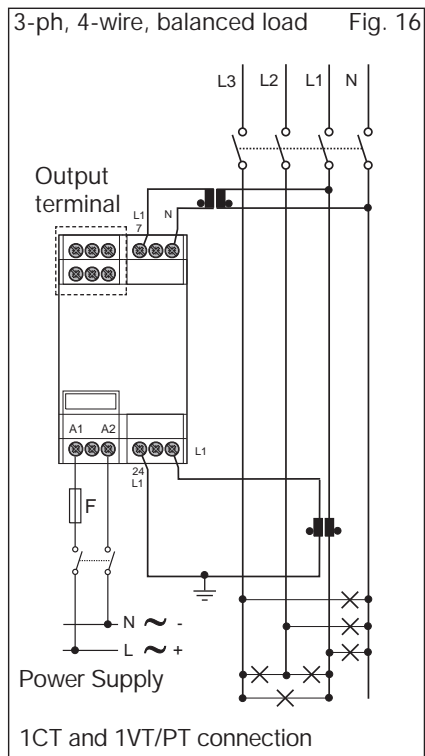

Analogue output 0-20mA

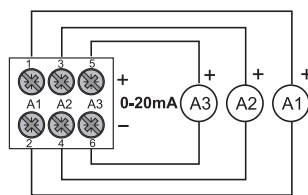

Fig. 17

Analogue output 0-10V

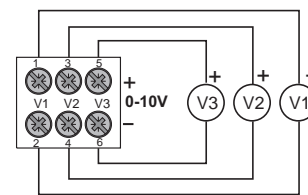

Fig. 18

Relay out.

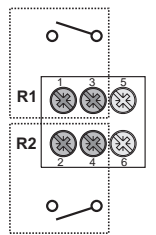

Fig. 19

NOTE: the analogue outputs are not insulated among each other.

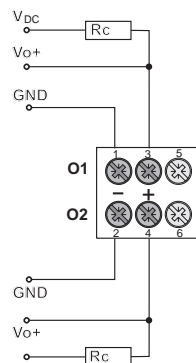

Fig. 20

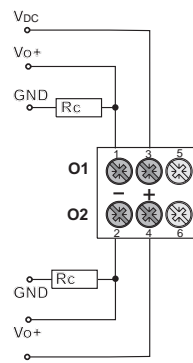
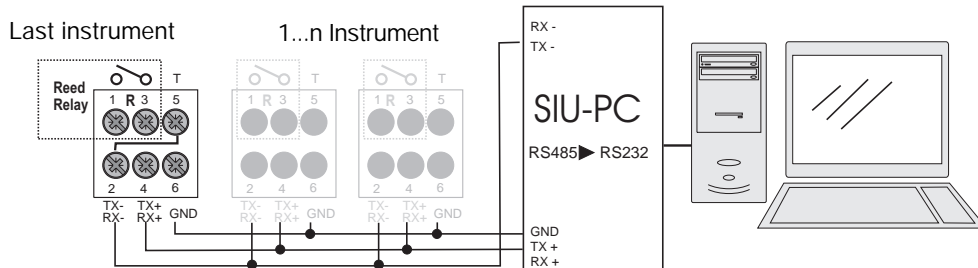

Fig. 21

Open collector outputs: The load resistance (R_c) must be calculated so that the closed contact current is lower than 100mA; the VDC voltage must be lower than or equal to 30V. VDC: power supply voltage (external). Vo+: positive output contact (open collector transistor). GND: ground output contact (open collector transistor).

RS485 serial port and one relay connections



2-wire connection of RS485 serial port + one relay (R). The terminalization must be carried out only on the last instrument of the network

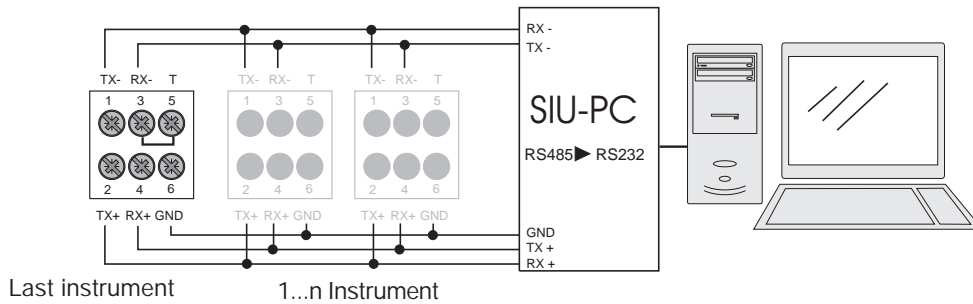

4-wire connection of RS485 serial port, the terminalization must be carried out only on the last instrument of the network

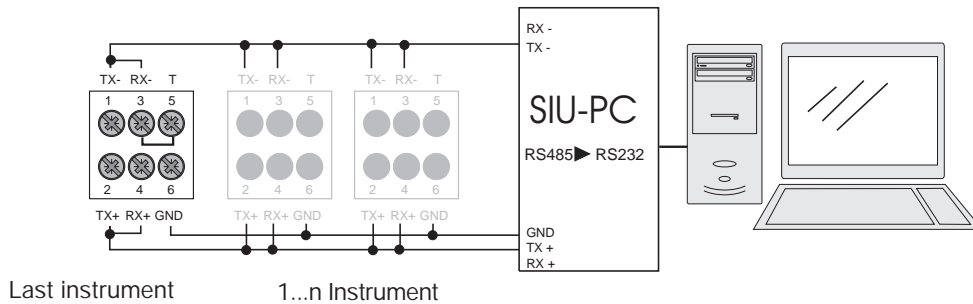

2-wire connection of RS485 serial port, the terminalization must be carried out only on the last instrument of the network

RS232 Serial port connection

Easy programming

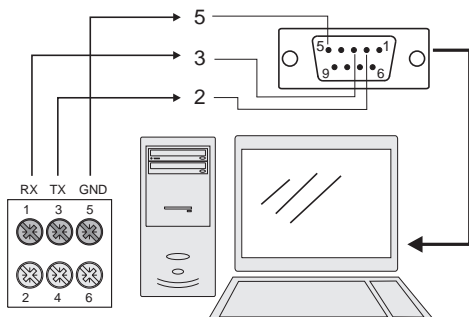

RJ12 communication port for parameters programming. The configuration of the transducer can be easily performed by means of CptASoft. CptASoft-kit includes also 1m long connection cable (RJ12 6-pole / RS232 9-pole female).

Outputs connections

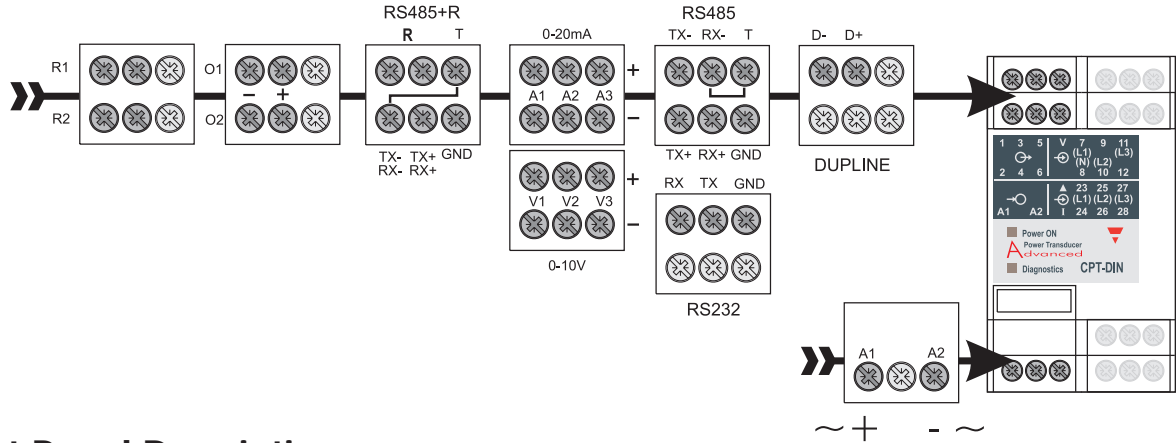

Front Panel Description

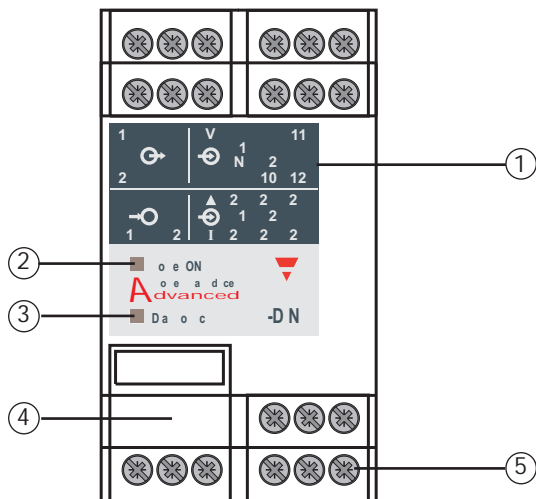

1. Front panel
2. Power ON LED
3. Diagnostics LED
4. Configuration bus (RJ12 connector)
5. Connections screw terminals

Dimensions

