

Photoelectrics Amplifier, μ -Processor Controlled Type S1430 RAL, 3 Inputs/3 Relay Outputs

CARLO GAVAZZI



- μ -Processor controlled
- Amplifier unit for 3 sets of photoelectrics
- 3 independent outputs with 1 x Relay SPDT, make switching funktion
- Self-diagnostic functions
- Alignment failure indication
- Multivoltage 15 to 30 VAC/DC
- Modulated and synchronized light
- Adjustable sensitivity for each channel
- LED indications: supply, outputs, signal quality
- 11-pin plug-in housing
- For 115 or 230 VAC use power supplies from SS120 series

Product Description

μ -Processor controlled amplifier for 3 sets of photoelectric sensors, type MOFTR, MKFTR, MIFTR or MHFTR. Utilising an 11-pin circular plug for easy connection. Relay outputs (NO). Self-diagnostics for system test.

Protected against reverse wiring or cross talk from adjacent photoelectrics. Multi-voltage power supply. Sensitivity is individually adjustable for each set of photoelectrics.

Ordering Key

S14 30 RAL 915

Type _____
 Special function _____
 Output type _____
 Power supply _____

Type Selection

Plug type	Ordering no. Supply: 15 - 30 VAC/DC
Circular, 11 pins	S 1430 RAL 915

Specifications

Rated operational voltage (U_B) pins 2 & 10	DC AC	13.5 to 33 VDC 13.5 to 33 VAC, 45 to 65 Hz
Rated operational power AC supply DC supply		5 VA 5 W
Power ON delay (t_v)		< 300 ms
Output Contact Rating (AgCdO)		
Resistive loads	AC 1 DC 1	1.5 A/100 VAC 1.5 A/30 VDC
Small induc. loads	AC 15 DC 13	1.5 A/100 VAC 1.5 A/30 VDC
Mechanical life (typical)		$\geq 20 \times 10^6$ operations at 18000 imp/H
Electrical life (typical)		≥ 300000 operating at 220 VAC - 2A resistive load
Output function		Relay Make function
Protection, outputs		Reverse polarity, short-circuit, transients
Supply to photoelectric switch Emitter		Tx1: Pin 1 Tx2: Pin 9 Tx3: Pin 6 Shield: Pin 11 (common)

Supply to photoelectric switch Emitter (cont.)		
Supply voltage (open loop)		7 V square wave
Current		≤ 300 mA short-circuit protected
Output resistance		10 Ω
Receiver		
		Rx1: Pin 4 Rx2: Pin 7 Rx3: Pin 8 Shield: Pin 5 (common)
Supply voltage (open loop)		5 VDC
Short-circuit current		10 mA
Input resistance		470 Ω
Sensitivity (% of S_n)		<ul style="list-style-type: none"> • 2 ranges, DIP-switch selectable - low sensitivity (25%) - high sensitivity (100%) • Sensitivity adjustment with 270°: Turn knob on CH 1, 2, 3 • Maximum range indicated on photoelectric switch data sheet in high sensitivity range only • Operation within low sensitivity range, increases ambient light and cross-talk immunity
Note:		



Specifications (cont.)

Operating frequency (f) Light/dark ratio 1:1	12.5 Hz
Response time OFF-ON (t _{ON}) ON-OFF (t _{OFF}) Multiplex cycle time	30 ms 30 ms 20 ms
Indication Supply ON Output ON Signal quality Multiplex activated	LED, green LED, yellow LED, red LED, yellow
Environment Overvoltage category Degree of protection Pollution degree	III (IEC 60664) IP 20 (IEC 60529, 60947-1) 3 (IEC 60664/60664A, 60947-1)
Temperature Operating Storage	-20° to +50°C (-4° to +122°F) -50° to +85°C (-58° to 185°F)
Weight	150 g
CE-marking	Yes

Truth Table

	Make switching		
Object present	Yes	No	No
Dirt on lenses, misaligned or sensitivity too low	--	No	Yes ¹⁾
Output LED yellow	OFF	ON	ON
Level LED red	OFF	OFF	ON or flashing
Output	OFF	ON	ON

¹⁾ Under normal operating conditions, the red level indication LED has to be OFF. The level indication LED will turn on shortly each time an object enters or exits the sensing zone, even if the photoelectric switch is correctly installed and adjusted.

Procedure for Test Functions (Dip-switch Selection)

Transmitter test

(switch 1 in the up position)

When switch 1 is placed in the up position all yellow and red LED's on the front of the unit will flash simultaneously. Once the test is completed (approx. 3 scans) and a wiring fault is detected, such as reverse polarity or short-circuit, the transmitter that has the fault condition will be indicated by the red LED being continuously ON. If a fault condition is not existing then only the yellow LED will be ON. If a fault exists, correct the fault condition and then repeat the test, this will ensure proper wiring has been done. Always reset **switch 1** for normal operation of system when testing completed.

Receiver test

(switch 2 in the up position)

When switch 2 is placed in the up position all yellow and red LED's on the front of the unit will flash simultaneously. Once the test is completed (approx. 3 scans) and a wiring fault is detected, such as reverse polarity or short-circuit, the receiver that has the fault condition will be indicated by the red LED being continuously ON. If a fault condition is not existing then only the yellow LED will be ON. If a fault exists, correct the fault condition and then repeat the test, this will ensure proper wiring has been done. Always reset **switch 2** for normal operation of system when testing completed.

Function test

(switch 1 and 2 in the up position)

When switch 1 and 2 are both placed in the up position (simultaneously) the yellow and red LED's on the front of the housing will begin to flash simultaneously and then the LED's

will cycle from channel 1 to channel 2 and then to channel 3. Once the complete system scan is done the indication of the system condition will be displayed (see below). System test will continue until switches 1 and 2 are reset.

LED Indication

Yellow LED ON Red LED OFF	} System Test OK
Yellow LED ON Red LED ON	} Tx's and Rx's mismatched, e.g. Rx3 seeing Tx1
Yellow LED OFF Red LED ON	} Alignment error or beam obstructed by object
Yellow LED	} When max. 3 amplifiers are linked the LED flashes

Multiplex Mode

Multiplex mode is when having up to 3 amplifiers linked together via connection no. 3 in the 11-pole socket. The system activates amplifier no. 1 channel 1, 2 and 3. Then amplifier no. 2 channel 1, 2 and 3 and finally amplifier no. 3 channel 1, 2 and 3. Then back to

amplifier no. 1 etc. Operating frequency in a multiplex system is divided with the number of amplifiers used. Response time in a multiplex system is multiplied with the number of amplifiers used. When working in a multiplex system the yellow LED flashes.

Operation Diagram

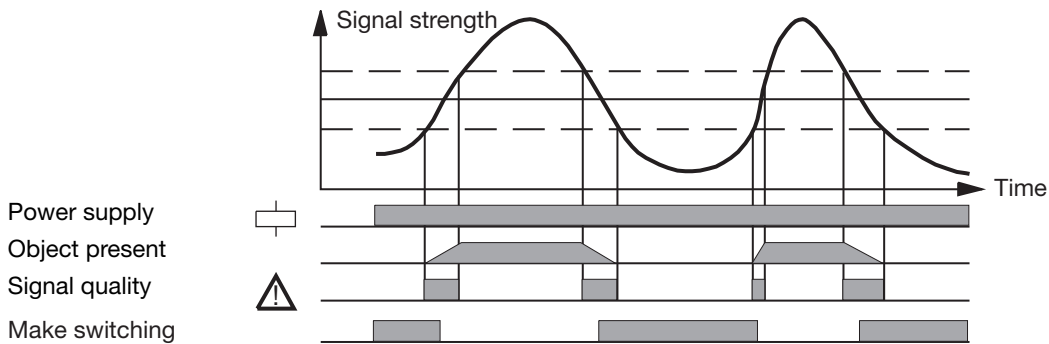

Dimensions

DIP-Switch (located behind cover):

SW 1 2 3 4 5 6

- 1: Make/break CH 1 output
- 2: Make/break CH 2 output
- 3: Make/break CH 3 output
- 4: Low sensitivity (25%) / high sensitivity (100%)
- 5: Test button, transmitters are transmitting, no short, wired correctly
- 6: Test button, receivers are receiving, no short, wired correctly
- 5+6 together: System test (transmitter and receiver)

<p>sw 1, 2, 3:</p> <ul style="list-style-type: none"> <input type="checkbox"/> Break <input type="checkbox"/> Make <p>sw 5:</p> <ul style="list-style-type: none"> <input type="checkbox"/> Transmitter test <input type="checkbox"/> Normal operation <p>sw 5+6:</p> <ul style="list-style-type: none"> <input type="checkbox"/> System test <input type="checkbox"/> Normal operation 	<p>sw 4:</p> <ul style="list-style-type: none"> <input type="checkbox"/> Range 25% <input type="checkbox"/> Range 100%, normal operation <p>sw 6:</p> <ul style="list-style-type: none"> <input type="checkbox"/> Receiver test <input type="checkbox"/> Normal operation
---	---

Wiring Diagrams

ON sockets

- 1: Transmitter 1
- 2: Supply (+ VDC)
- 3: Multiplex
- 4: Receiver 1
- 5: GND (Receivers)
- 6: Transmitter 3
- 7: Receiver 2
- 8: Receiver 3
- 9: Transmitter 2
- 10: Supply (- VDC)
- 11: GND (Transmitters)

Output coding

- A: } Output 1 (max. 30 VDC, 100 VAC, 1.5A)
- B: }
- C: } Output 2 (max. 30 VDC, 100 VAC, 1.5A)
- D: }
- E: } Output 3 (max. 30 VDC, 100 VAC, 1.5A)
- F: }

Wire colour

- white
- black
- red
- green
- yellow
- blue

Wiring Diagram, Multiplex Mode

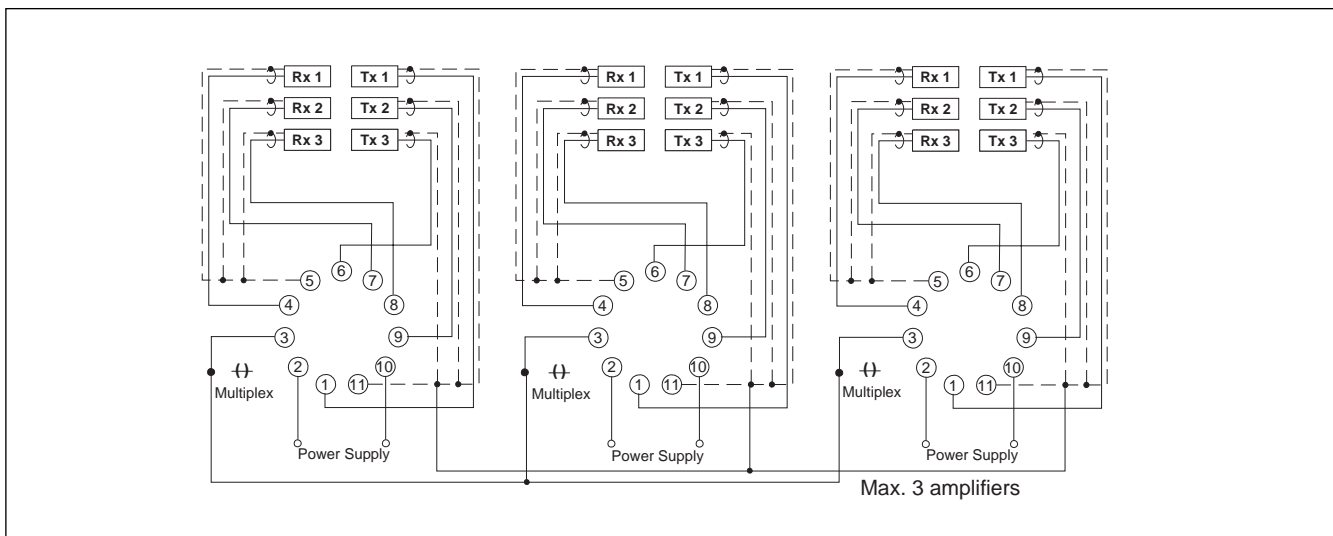

Accessories

- | | |
|--------------------------------|--------------------------|
| - 11 pole circular socket | S111, S111A, S411, ZPD11 |
| - Socket cover for S111 | BB1 |
| - Socket cover for S411 | BB4 |
| - Holding down spring | HF |
| - Mounting rack | SM13 |
| - Front panel mounting bezel | FRS2 |
| - Connection cable (2 plugs) | |
| 2 x 6/6 modular plugs | 2.0 m, 6 wires two plugs |
| - Power supply for 115/230 VAC | SS120-series |
| - DIN-rail interface | 6IODC |

Delivery Contents

- | | |
|---------------------------|--------------------------|
| • Output connection cable | 1 m, 6 wires one plug |
| • Output connection cable | 0.2 m, 6 wires two plugs |
| • Amplifier | S 1430 RAL 915 |
| • DIN-rail interface | 6IODC |
| • Screw driver | |
| • Packaging: | Cardboard box |

Interface

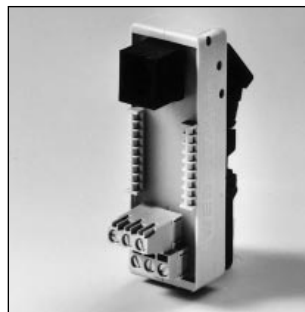

6IODC
DIN-rail interface
(DIN EN 50 035, EN 50 022)
Output from plug to screw terminals