

Photoelectrics, Fibre Optic Sensor Glass Fibres Type PD 60 CNV 20 BP .. T

CARLO GAVAZZI



- Range: Fibre dependent
 - Diffuse Reflective typ. 80 mm
 - Through Beam typ. 200 mm
- Teach-In (keyboard or remote setup)
- Keyboard set-up and multifunction LED
- Keyboard lock
- Microprocessor controlled and EEPROM parameter storage
- Operational voltage 10 - 30 V DC
- Output 100 mA, NPN and PNP
- Light or dark switching selectable
- Cable or M8 standard plug
- IP65 protection
- Timer: ON-delay or OFF-delay
- cUL and CE approved

Product Description

The PD60CNV20BP.. T is a fibre optic amplifier made specific for glass fibres with temperature up to 250° C. The sensor is microprocessor based and has a build in programmable functions such as Teach-In function for fast sensing distance optimising, NO or NC output, Time delay ON or OFF The sensor output is build as a Push-pull output that performs both a NPN and PNP output which are fully

protected against short-circuit, transients and wrong polarity. The sensor is build in a strong 13 x 30 x 60 mm polycarbonate housing for DIN-rail mounting. The sensors are suitable for applications that require little space and high accuracy such as: Small part detection, tight locations, checking parts, counting, precise part positioning, material handling and assembly and robotics

Ordering Key

PD 60 CNV 20 BP M5 T

Type	_____
Housing style	_____
Housing size	_____
Housing material	_____
Not Used	_____
Glass fibres	_____
Sensing distance cm	_____
Output type	_____
Output configuration	_____
Connection type	_____
Teach-In mode	_____

Type Selection

Housing W x H x D	Range S _n (Fibre dependent)	Ordering no. NPN and PNP cable Make or break switching	Ordering no. NPN and PNP plug Make or break switching
13 x 30 x 60 mm	80 mm diffuse mode 200 mm through beam mode	PD 60 CNV 20 BP T	PD 60 CNV 20 BP M5 T

Specifications

Rated operating distance (S_n) Diffuse mode Through beam mode	See optical fibre table Up to 80 mm Up to 200 mm	Voltage drop (U_d) I _L = 100 mA I _L = 10 mA	≤ 2 VDC ≤ 1 VDC
Sensitivity Teach-In Manual fine tune	Automatic threshold set-up Sensitivity increase or sensitivity decrease	Remote input ON OFF	≤ 1.4 VDC ≥ 3.0 VDC
Temperature drift	< 0,4%/C°	Timer Range programmable First step Following step	0 to 5 sec. in 11 steps 40 mS 500 mS
Hysteresis (H) Differential travel	≤ 5%	Protection	Short-circuit, reverse polarity, transients
Rated operational volt. (U_B)	10 to 30 VDC (ripple included)	Light source Light type Ambient light Incandescent light Sunlight	GaAIAs, LED 660 nm Red modulated 10'000 Lux 20'000 Lux
Ripple (U_{rpp})	≤ 10%		
Output current Continuous (I _a) Short-time (I)	100 mA 100 mA		
No load supply current (I_o)	≤ 40 mA		



Specifications (cont.)

Operating frequency	1 KHz	Temperature	
Response time		Operating	0° to +60°C (32° to +140°F)
OFF-ON (t_{ON})	≤ 500 μS	Storage	-20° to +80°C (-4° to +176°F)
ON-OFF (t_{OFF})	≤ 500 μS	Vibration	10 to 150 Hz, 0.5 mm/7.5 g (IEC60068-2-6)
Power ON delay (t_v)	≤ 300 mS	Shock	2 x 1 m & 100 x 0.5 m (IEC 60068-2-6, 60068-2-32)
Output function		Rated insulation voltage	50 VAC (rms)
NPN and PNP	Available (Push-pull output)	Housing material	
Make or break	Programming by keyboard	Body	Polycarbonate
Indication function		Connection	
Target detected, timer ON, sensitivity, alignment, low signal, keyboard lock, short circuit		Cable	PVC, grey, 2 m, 4 x 0,25 mm ²
Environment		Plug	NPB, M8 x 1
Installation category	1 (IEC 60664/60664A;60947-1)	Cables for plug (M5)	CONG5A-series
Pollution degree	3 (IEC 60664/60664A;60947-1)	Weight	24 g
Degree of protection	IP 65 (IEC 60529; 60947-1)	Approvals	cUL
		CE-marking	Yes

Operation Diagram

t_v = Power ON delay

Power supply

Target present

Break (NC) Output ON

Make (NO) Output ON

ON Delay (NO-output)

OFF Delay (NO-output)

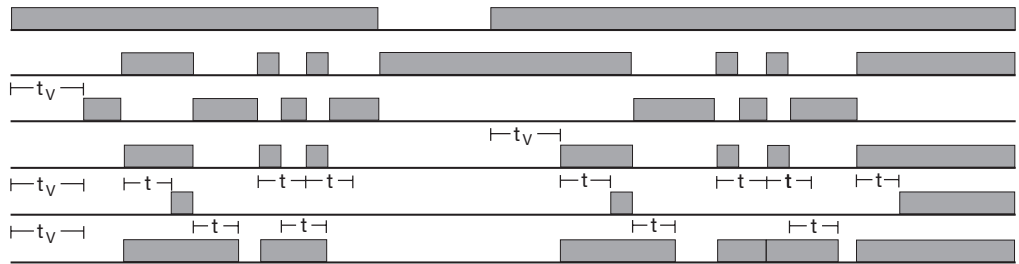

Dimensions

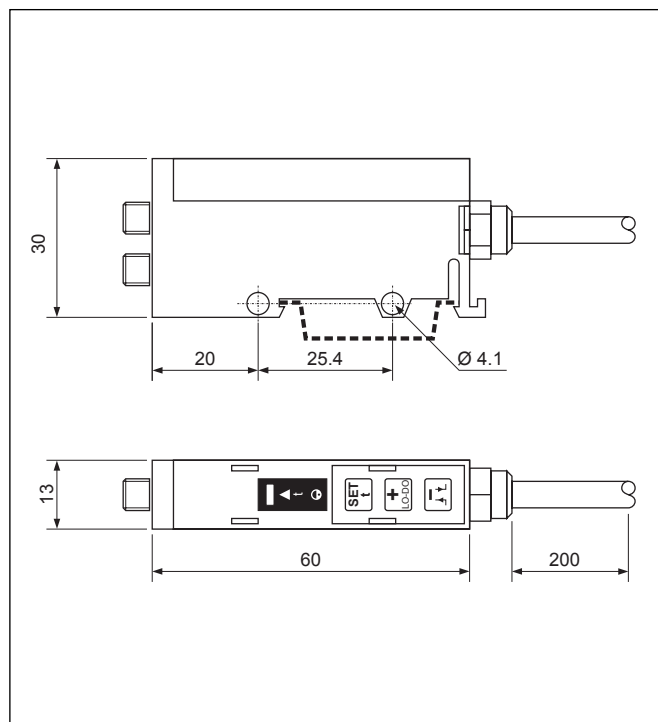
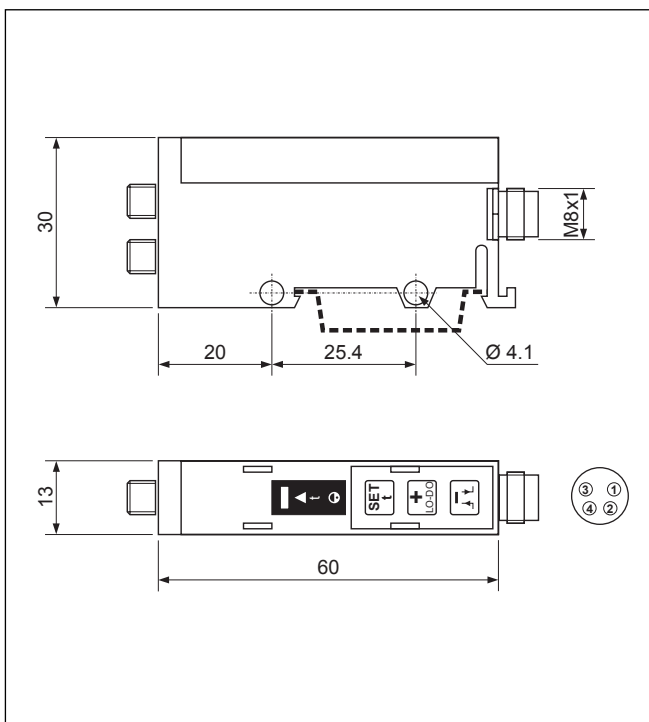

Programming Functions

Keyboard Unlock	Press &	Timing functions ON delay	Press for 4 sec.
	for 4 sec. and the indicator turn OFF		Until the flashes
Lock	Press &	Set timer (timer ON)	Press N times
	for 4 sec. and the indicator turn ON	Increase time (500 mS/step)	Press N times
Self-Teach operation Coarse set-up mode	Press one time	Decrease time (500mS/step)	Press for 4 sec.
	Fine set-up mode (Similar to Remote Input)	ON or OFF delay (toggle)	Press two times
Sensitivity adjustment To increase	Press N time	Reset timer (timer OFF)	Press for 4 sec.
	To decrease	Exit timer setting	Press for 4 sec.
Light or dark operation Change the output function	Press for 4 sec.	Alignment help Enter alignment help	Press for 4 sec.
		Exit alignment help	Until the flashes Three frequencies proportional to the signal strength
			Press for 4 sec.

Wiring Diagram

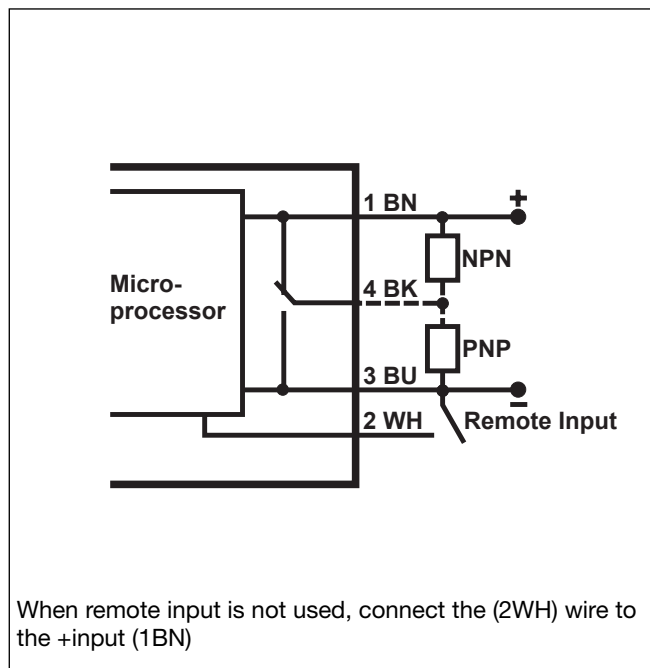

Keyboard and LED

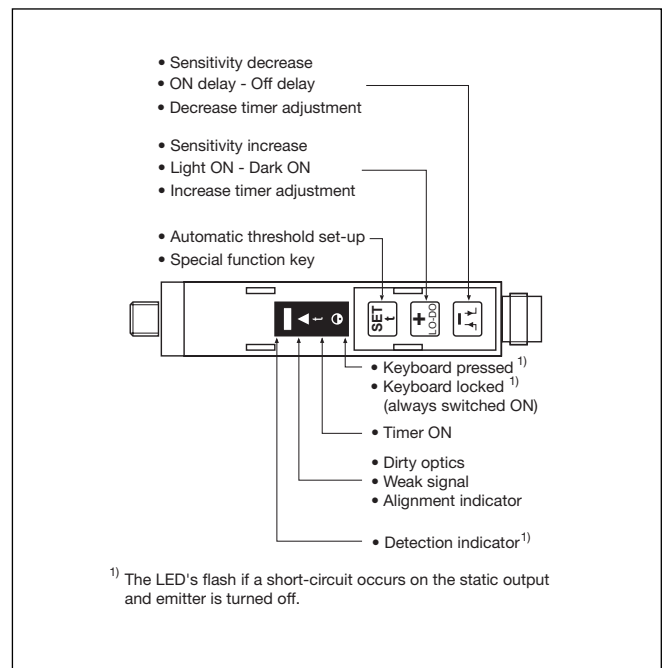

Installation Hints

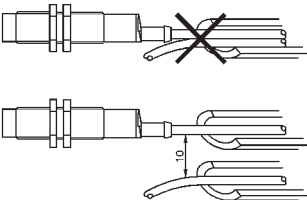
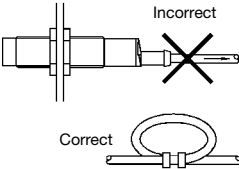
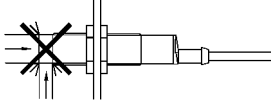
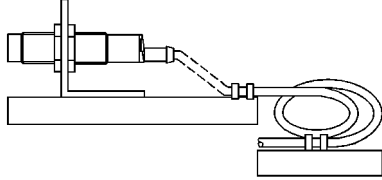
<p>To avoid interference from inductive voltage/current peaks, separate the prox. switch power cables from any other power cables, e.g. motor, contactor or solenoid cables</p> 	<p>Relief of cable strain</p>  <p>The cable should not be pulled</p>	<p>Protection of the sensing face</p>  <p>A proximity switch should not serve as mechanical stop</p>	<p>Switch mounted on mobile carrier</p>  <p>Any repetitive flexing of the cable should be avoided</p>
---	---	---	--

Delivery Contents

- Photoelectric switch: PD60CNV20BP..T
- Installation instruction
- **Packaging:** Cardboard box

Accessories

- Plastic fibres type FGD., FGT..
- Connector type: CONG5A..

For further information refer to “Accessories”