

Proximity Inductive Sensors Extended range, Nickel-Plated Brass Housing Types ICB, M30



- Sensing distance: 15 to 22 mm
- Flush and non-flush types
- Short and long body versions
- Rated operational voltage (U_b): 10 - 36 VDC
- Output: DC 200 mA, NPN or PNP
- Normally open, Normally closed
- LED indication for output ON
- Protection: reverse polarity, short circuit, transients
- Cable and M12 plug versions
- According to IEC 60947-5-2

Product Description

A family of inductive proximity switches in industrial standard nickel-plated brass housings. They are able to handle applications where

high sensing range is requested. Output is open collector NPN or PNP transistors.

Ordering Key

ICB30SF15NOM1

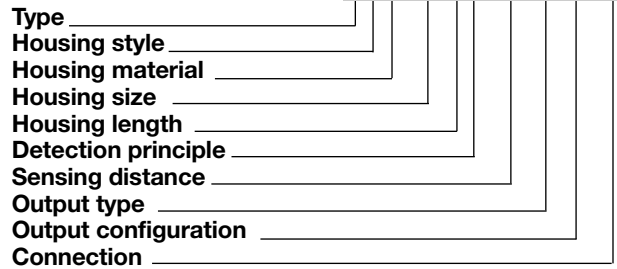

Type Selection

Conne- ction	Body style	Rated operating distance S_n	Ordering no. NPN Normally open	Ordering no. PNP Normally open	Ordering no. NPN Normally closed	Ordering no. PNP Normally closed
Cable	Short	15 mm ¹⁾	ICB 30 SF 15 NO	ICB 30 SF 15 PO	ICB 30 SF 15 NC	ICB 30 SF 15 PC
Cable	Short	22 mm ²⁾	ICB 30 SN 22 NO	ICB 30 SN 22 PO	ICB 30 SN 22 NC	ICB 30 SN 22 PC
Plug	Short	15 mm ¹⁾	ICB 30 SF 15 NOM1	ICB 30 SF 15 POM1	ICB 30 SF 15 NCM1	ICB 30 SF 15 PCM1
Plug	Short	22 mm ²⁾	ICB 30 SN 22 NOM1	ICB 30 SN 22 POM1	ICB 30 SN 22 NCM1	ICB 30 SN 22 PCM1
Cable	Long	15 mm ¹⁾	ICB 30 LF 15 NO	ICB 30 LF 15 PO	ICB 30 LF 15 NC	ICB 30 LF 15 PC
Cable	Long	22 mm ²⁾	ICB 30 LN 22 NO	ICB 30 LN 22 PO	ICB 30 LN 22 NC	ICB 30 LN 22 PC
Plug	Long	15 mm ¹⁾	ICB 30 LF 15 NOM1	ICB 30 LF 15 POM1	ICB 30 LF 15 NCM1	ICB 30 LF 15 PCM1
Plug	Long	22 mm ²⁾	ICB 30 LN 22 NOM1	ICB 30 LN 22 POM1	ICB 30 LN 22 NCM1	ICB 30 LN 22 PCM1

¹⁾ For flush mounting in metal

²⁾ For non-flush mounting in metal

Specifications

Rated operational voltage (U_b)	10 to 36 VDC (ripple incl.)	Assured operating sensing distance (S_a)	$0 \leq S_a \leq 0.81 \times S_n$
Ripple	$\leq 10\%$	Effective operating distance (S_r)	$0.9 \times S_n \leq S_r \leq 1.1 \times S_n$
Output current (I_o)	≤ 200 mA @ 50°C (≤ 150 mA @ 50-70°C)	Usable operating distance (S_u)	$0.85 \times S_r \leq S_u \leq 1.1 \times S_r$
OFF-state current (I_i)	≤ 50 μ A	Repeat accuracy (R)	$\leq 5\%$
No load supply current (I_o)	≤ 15 mA	Differential travel (H) (Hysteresis)	1 to 20% of sensing dist.
Voltage drop (U_d)	Max. 2.5 VDC @ 200 mA	Ambient temperature Operating Storage	-25° to +70°C (-13° to +158°F) -30° to +80°C (-22° to +176°F)
Protection	Reverse polarity, short-circuit, transients	Housing material Body Front	Nickel-plated brass Grey thermoplastic polyester
Dielectric impulse voltage withstand	1 kV/0.5 J		
Power ON delay (t_o)	300 ms		
Operating frequency (f)	≤ 1000 Hz		
Indication for output ON	LED, yellow		

Specifications (cont.)

Connection Cable	2 m, 3 x 0.3 mm ² , grey PVC, oil proof M12 x 1
Plug	
Degree of protection	IP 67
Weight (cable/nuts included)	
ICB30 S	Max. 185 g
ICB30 L	Max. 195 g
Dimensions	See diagrams below
Tightening torque	50 Nm

Approvals	UL
CE-marking	Yes
EMC protection IEC 6100-4-2 (ESD)	According to IEC 60947-5-2 8 KV air discharge, 4 KV contact discharge 3 V/m 2 kV 3 V 30 A/m
IEC 6100-4-3	
IEC 6100-4-4	
IEC 6100-4-6	
IEC 6100-4-8	

Dimensions

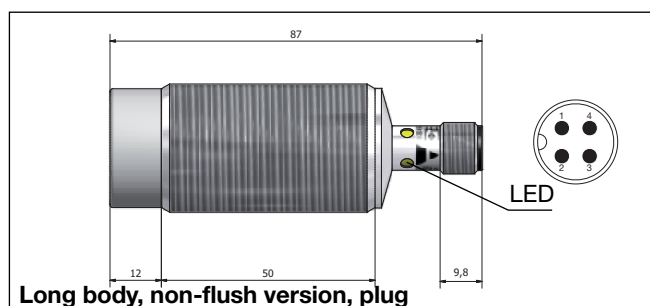
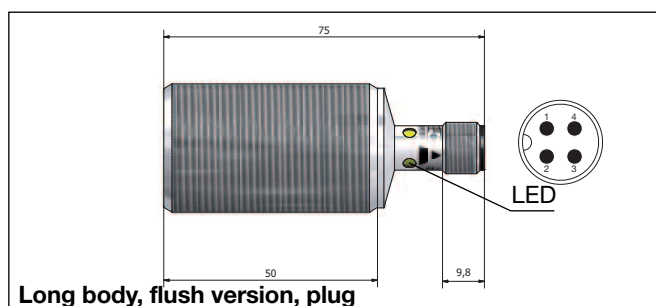
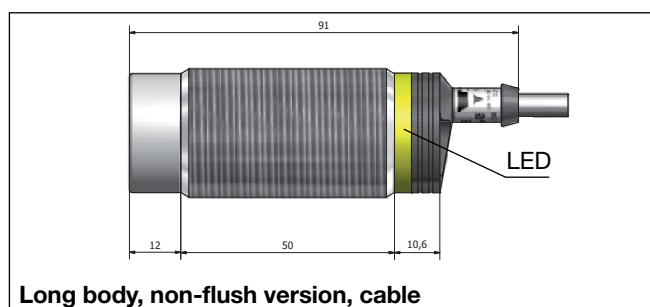
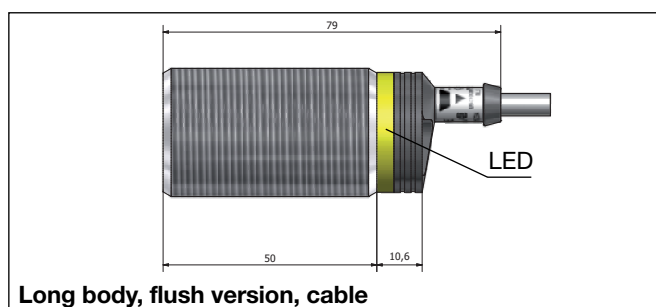
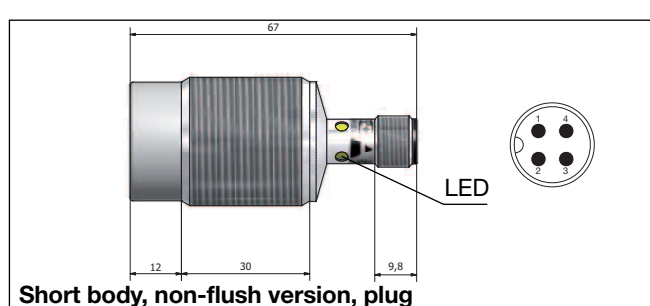
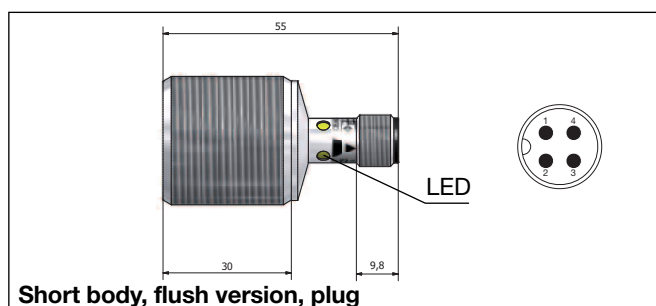
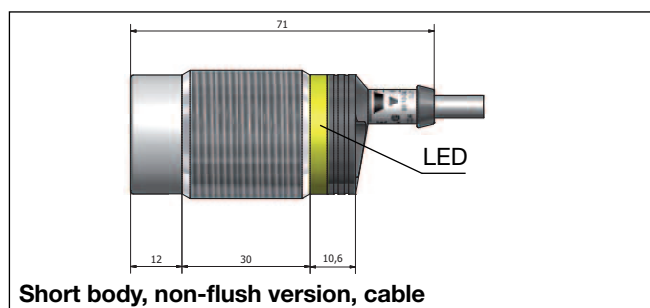
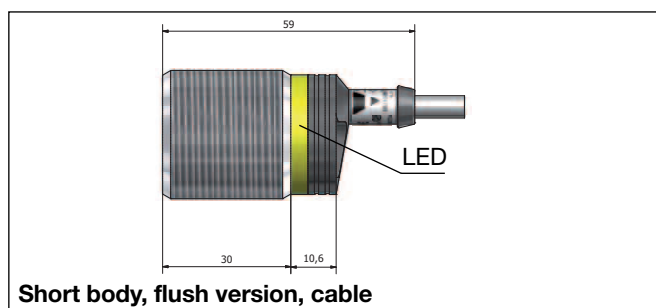

Wiring Diagrams

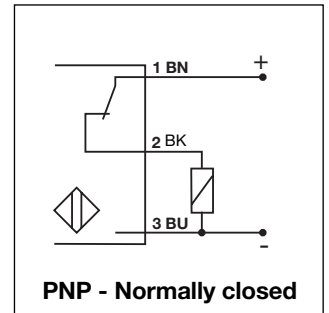
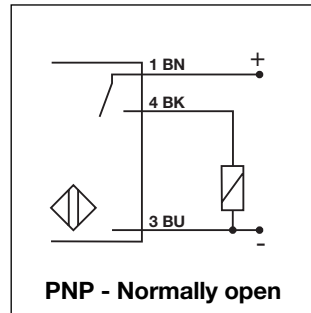
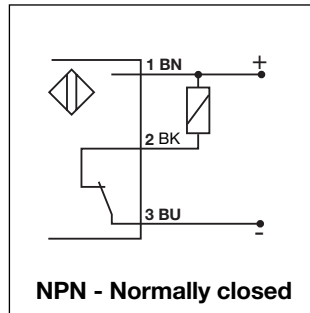
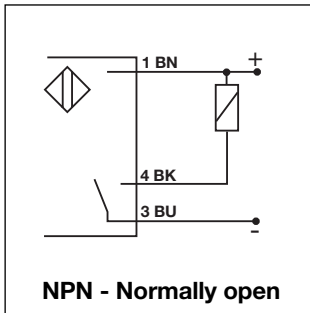

Installation

Flush sensor, when installed in damping material, must be according to Picture 1A.

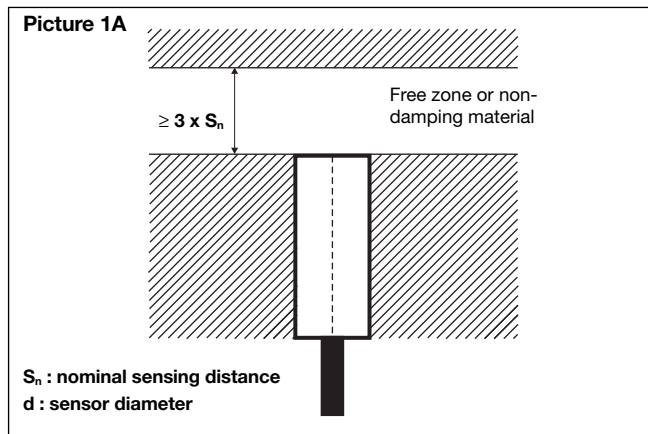

Non-flush sensor, when installed in damping material, must be according to Picture 1B.

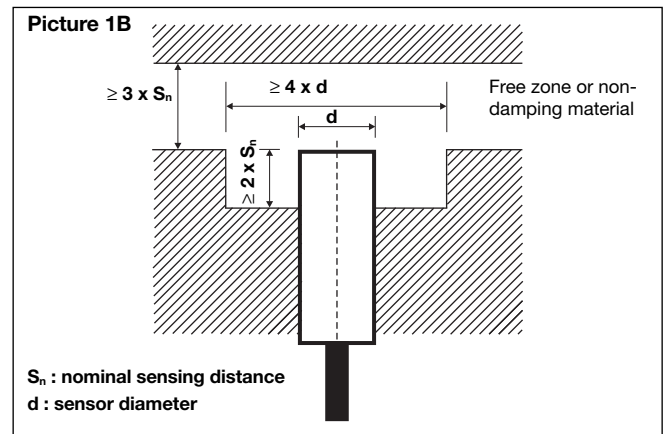

Flush sensors, when installed together in damping material, must be according to Picture 2A.

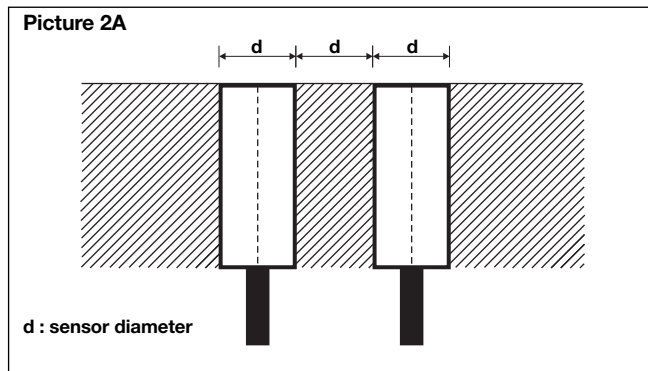

Non-flush sensors, when installed together in damping material, must be according to Picture 2B.

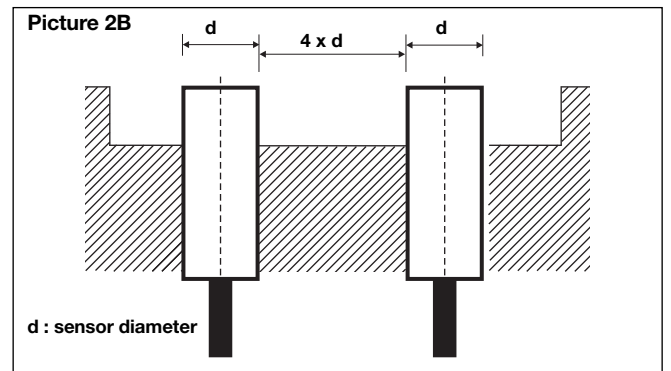

For sensors installed opposite each other, a minimum space of $6 \times S_n$ (the nominal sensing distance) must be observed (See Picture 3).

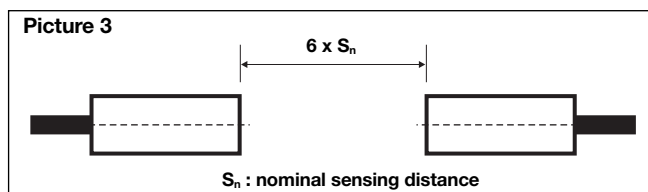

Reduction factors

The rated operating distance is reduced by the use of metals and alloys other than Fe360.

The most important reduction factors for inductive proximity sensors are shown in Picture 4.

Delivery Contents

- Inductive proximity switch ICB.
- 2 nuts NPB
- Packaging: plastic bag

