

# Motor Controllers

## AC Semiconductor Motor Controller

### Type RSHR



- Soft starting and stopping of 3-phase squirrel cage motors
- Low inrush and reduced vibration during starting
- Integrated bypassing of semiconductors
- Rated operational voltage: up to 600 VAC, 50/60 Hz
- Rated operational current up to 45A AC-53b
- LED status indicators
- Motor PTC protection
- Device over-temperature protection
- DIN rail or panel mounting

### Product Description

Compact easy-to-use AC semiconductor motor controller. With this controller 3-phase motors with nominal load currents up to 45 A can be soft-started and/or soft-stopped. Starting and stopping time as well as initial torque can be independently adjusted by built-in potentiometers.

### Ordering Key

**RSH R 48 45 C V20**

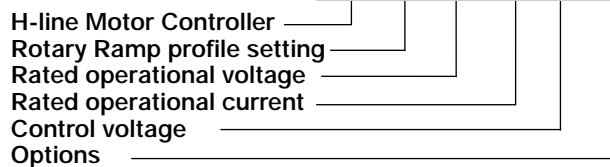

### Selection Guide

Rated operational voltage $U_e$	Rated operational current $I_e$			Options
	25A AC-53b	38A AC-53b	45A AC-53b	
220VACrms	RSHR2225CV20	RSHR2238CV20	RSHR2245CV20	V20: Basic
400VACrms	RSHR4025CV20	RSHR4038CV20	RSHR4045CV20	V21: 2 auxiliary relays
480VACrms	RSHR4825CV20	RSHR4838CV20	RSHR4845CV20	
600VACrms	RSHR6025DV20	RSHR6038DV20	RSHR6045DV20	

### Supply Specification

Rated operational voltage $U_e$ through L1, L2, L3	RSHR22.. 127/220 VAC -15% /+10%
	RSHR40.. 230/400 VAC -15% /+10%
	RSHR48.. 277/480 VAC -15% /+10%
	RSHR60.. 346/600 VAC -15% /+10%
Rated AC frequency	50/60 Hz±10%
Dielectric strength	
Dielectric voltage	2 kV (rms)
Rated impulse withstand volt.	4 kV (1.2/50µs)

### Input Specifications

Rated control input voltage $U_c$ , A1-A2:	C: 24-500 VAC/DC D: 24-600 +10% VAC/DC
Rated control input current	<1.5 mA
Rated AC frequency	50/60 Hz±10%
Dielectric strength	
Dielectric voltage	2kVAC (rms)
Rated impulse withstand volt.	4kV (1.2/50 µs)

### Load Ratings

	RSHR..25....	RSHR..38....	RSHR..45....
IEC rated operational current $I_e$ (AC-53b)	25 A	38A	45 A
Assigned motor rating @ 60°C/ UL rating @ 60°C			
RSHR22..	5.5kW / 10HP	11kW / 10HP	11kW / 15HP
RSHR40..	11kW / 15HP	18.5kW / 20HP	22kW / 25HP
RSHR48..	15kW / 20HP	22kW / 25HP	30kW / 30HP
RSHR60..	18.5kW / 25HP	22kW / 30HP	30kW / 40HP
Overload cycle according to IEC/EN 60947-4-2 @ 40°C	25A:AC-53b:4-5:65	38A: AC-53b: 4-5:85	45A: AC-53b: 4-5: 115
@ 50°C	25A:AC-53b:4-5:85	38A:AC-53b:4-5:175	45A: AC-53b: 4-5: 135
@ 60°C	25A:AC-53b:4-5:175	38A:AC-53b:4-5:355	45A: AC-53b: 4-5: 175
Number of starts per hour @ 40°C/50°C/60°C	50/35/20	40/20/10	30/25/20
Minimum load current	500mA	500mA	500mA

## Conductor Data

<b>Line conductors:</b> <b>L1, L2, L3/T1, T2, T3</b> according to IEC 60947	0.75...16mm <sup>2</sup>
maximum size	
solid	1.5...16mm <sup>2</sup>
finely stranded with end sleeve	1.5...16mm <sup>2</sup>
stranded	1.5...25mm <sup>2</sup>
<b>UL/CSA rated data</b>	
UL rated data	AWG 14...4
CSA rated data	AWG 10...6
Terminal screws	6xM5 (cage clamp)
Tightening torque	1.5...2.5 Nm /13...22 lb.in
CSA data	max. 3.0Nm/ 26.5 lb/in
Stripping length	10 mm
<b>Secondary conductors:</b> <b>A1, A2, 11, 21, 22, P1, P2</b> according to IEC 60947	0.75...2.5mm <sup>2</sup>
maximum size	0.5...2.5mm <sup>2</sup>
UL/CSA rated data	AWG 22...14
Terminal screws	7xM3 (cage clamp)
Tightening torque	0.3...0.5 Nm/2.7...4.5 lb.in
Stripping length	6 mm

## Thermal Specifications

Operating temperature	-20° to +60°C (-4° to +140°F)
Storage temperature	-50° to +85°C (-58° to +185°F)

## Standards

Approvals	UL, cUL, CSA
Markings	CE
Norms	IEC/EN 60947-4-2

## General Specifications

Pollution degree	3
Weight	800g (approx.)
Degree of protection	IP20 (IEC 60529)
Relative humidity	<95% non-condensing
Ramp up time	1...10s
Ramp down time	1...30s
Initial torque	0...70%
<b>Status indicator LEDs</b>	
Power supply ON	LED, green (continuous)
Ramping	LED, yellow (intermittent)
Bypass relay ON	LED, yellow (continuous)
Over-temperature alarm	
Device alarm	LED, red (intermittent)
Motor PTC alarm	LED, red (continuous)
Wrong phase sequence*	LED, red (intermittent)
Phase loss	
Phase loss alarm*	LED, red (blinking at 4Hz)
Under voltage alarm	LED, red (blinking at 1.3Hz)
Motor PTC alarm input P1, P2	Acc. to DIN 44081 and DIN 44082-1
Form designation	Form 1
<b>Auxiliary relays: (V21 option)</b>	
Bypass relay activation	Normally open (21,22)
Over-temperature, phase sequence, phase loss alarm	Normally closed (11, 22)
Auxiliary relay contact capacity	3 A, 250 VAC 3 A, 30 VDC
Installation altitude	Above 1000m derate linearly by 1% of unit FLC per 100m to a maximum altitude of 2000m

\* detection of these alarm conditions is made during power-up of the device

## Recommended Protection according to IEC/EN 60 947-4-2

	RSHR..25....	RSHR ..38....	RSHR..45....
Type of coordination: 2 Semiconductor fuse	Ferraz Shawmut 63A, Class URQ, Art.No. 6.621 CP URQ27x60/63	Ferraz Shawmut 80A, Class URQ, Art.No. 6.621 CP URQ27x60/80	Ferraz Shawmut 100A, Class URQ, Art.No. 6.621 CP URQ27x60/100
Type of coordination: 1 Motor protection circuit breaker	ABB: MS325 -25 Telemecanique: GV2-M22 Sprecher+Schuh: KTA3-25-25A	ABB: MS450 -40 Telemecanique: GV3-ME40 Sprecher+Schuh: KTA3-100-40A	ABB: MS450 -45 Telemecanique: GV3-ME63 Sprecher+Schuh: KTA3-100-63A
RK5 fuse	TRS45R 45A	TRS70R 70A	TRS90R 90A

# Wiring Diagram

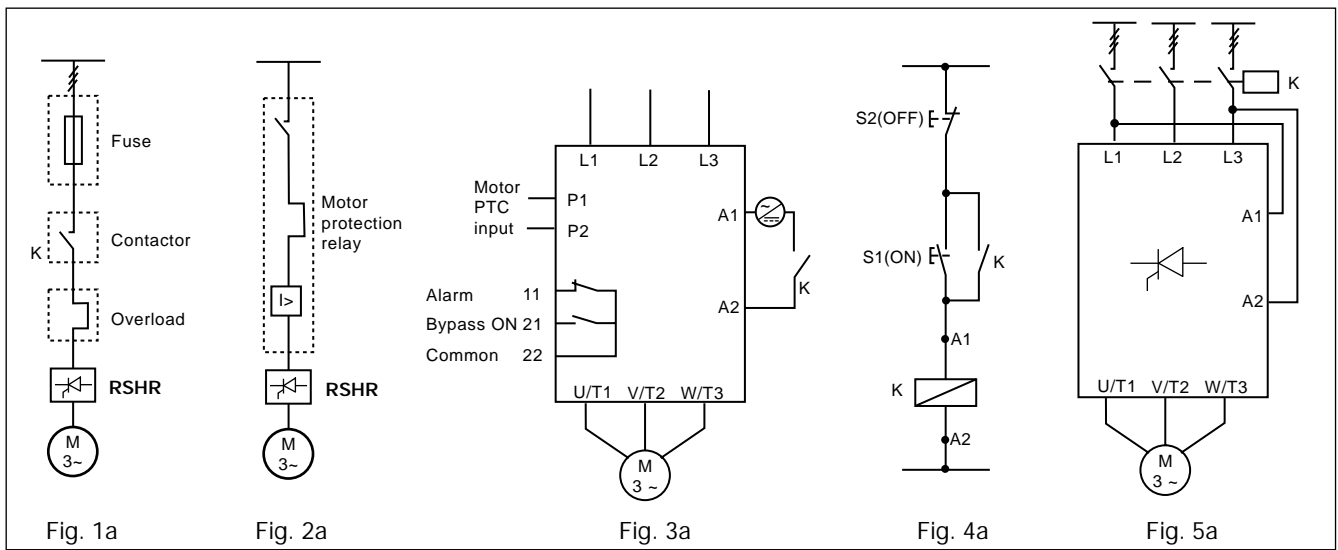

IEC

The motor controller provides by-passing of the semiconductors during running operation. Therefore the semiconductors can only be damaged by short-circuit currents during ramp-up and ramp-down. Please note that the motor controller does not isolate the motor from the mains.

**Figure 1: Protection of the device when using fuses.**

Protection with semiconductor fuses is intended to protect the motor feeder and motor controller from damage due to short-circuit.

**Figure 2: Protection using a thermal-magnetic motor protection relay.**

The motor feeder is protected but damage to the motor controller is possible. When motor failure occurs, if part of the motor winding limits the fault current and the motor feeder is protected, this type of protection can be considered acceptable.

**Figure 3: Secondary conductors.**

3.1: Control using a 2-position switch. When K is closed, the control

input is supplied to A1, A2 and soft starting of the motor is performed. When K is opened, soft stopping is performed.

3.2: Motor PTC input. When the motor PTC sensor is connected to P1, P2 the motor controller detects overheating of the motor windings.

3.3: Auxiliary Relays (Available on RSHR...V21 types only!) The Alarm relay 11, 22 (NC) can be connected in series with the supply to the coil of a mains contactor. The Bypass ON relay 21, 22 (NO) can be used in series with the supply

to the coil of an external bypass contactor.

**Figure 4: Control using ON and OFF push buttons**

Pushing S1 soft starts the RSHR. Pushing S2 soft stops the RSHR. K is an auxiliary contact of the mains contactor.

**Figure 5: Control using 2 phases**

Connecting input A1, A2 to two of the incoming lines will soft start the motor when K is operated. When K is switched off, the motor will stop (no soft stop).

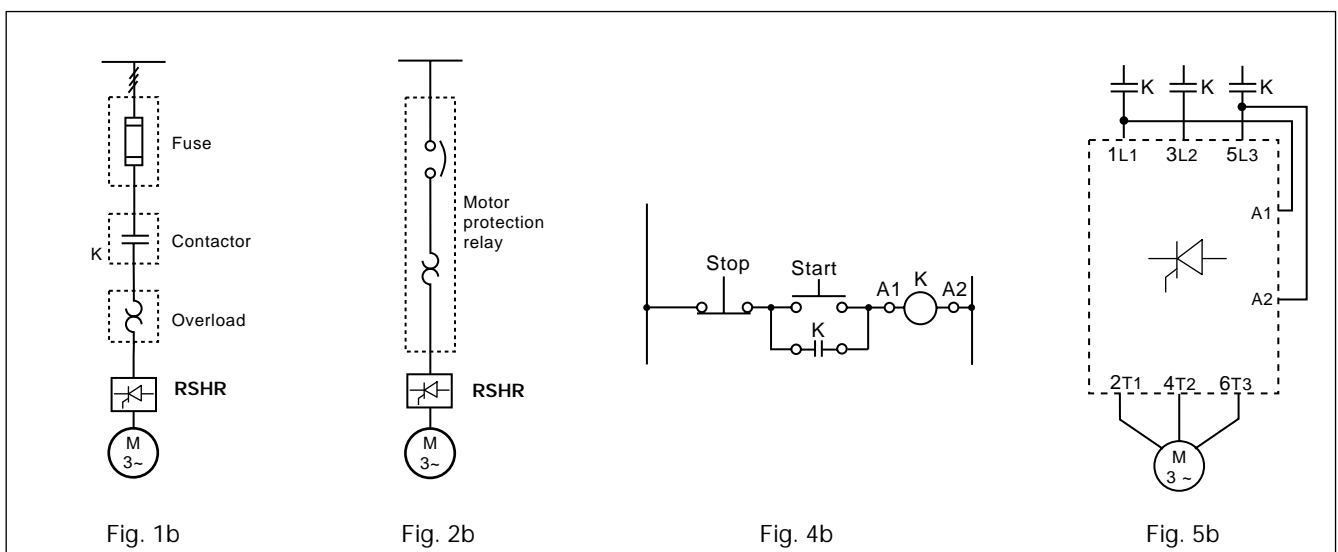

NEMA



### Dimensions

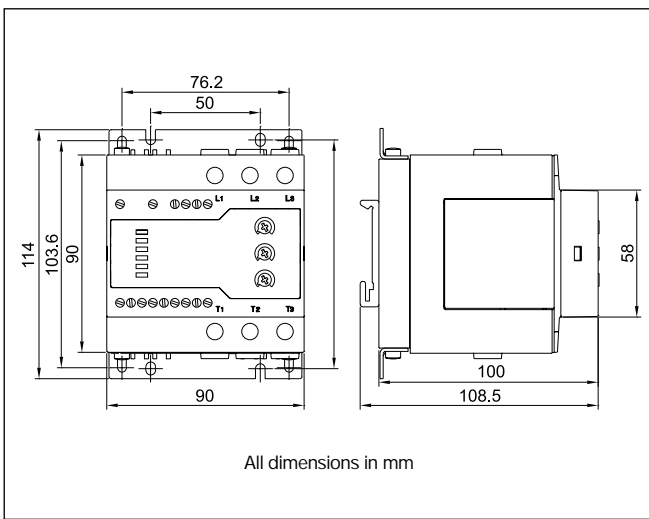

### Terminal Diagram

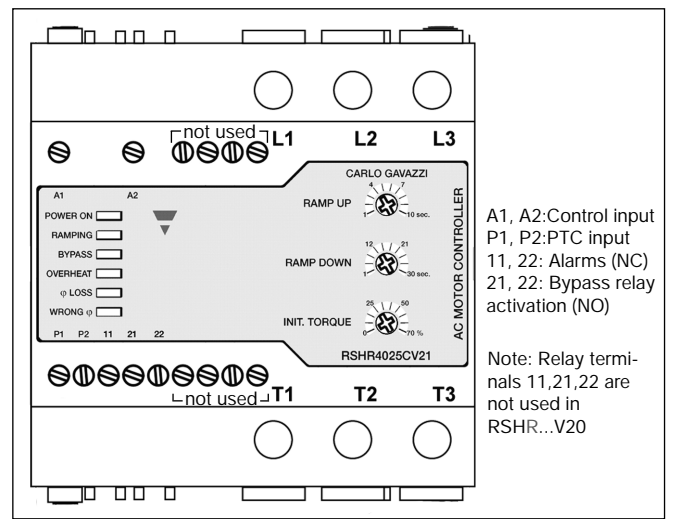

### Operation Diagram

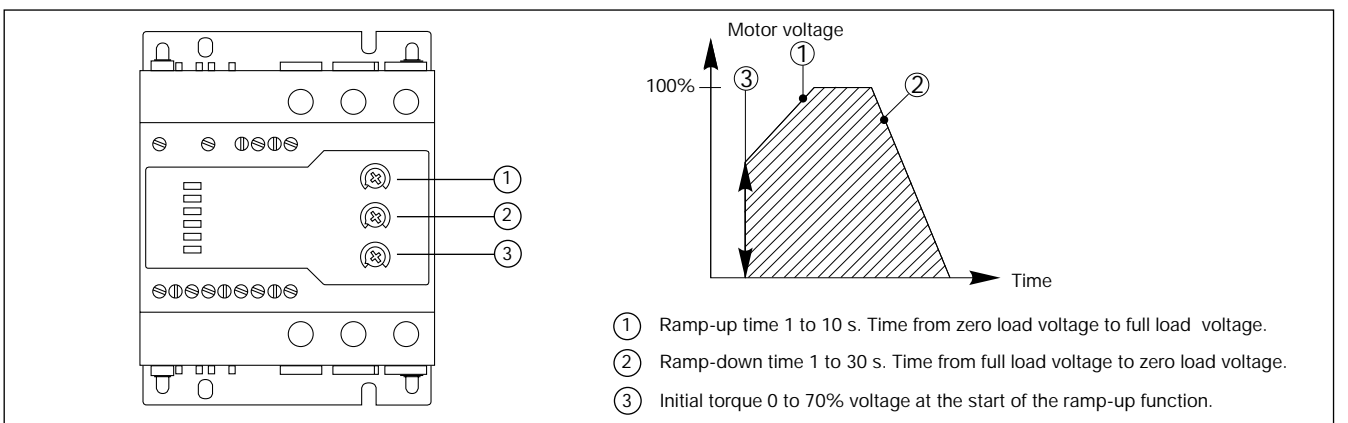

## Operation Diagrams for RSHR

**Diagram 1: Normal Operation**

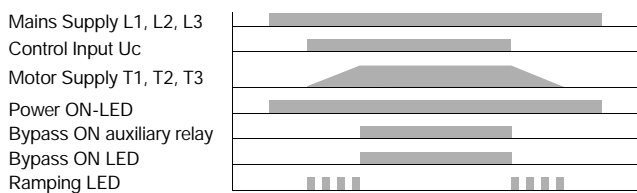

**Diagram 2a: Device over-temperature alarm**

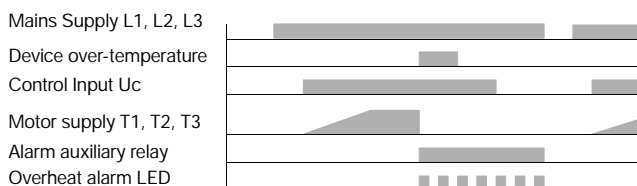

**Diagram 2b: Motor PTC alarm**

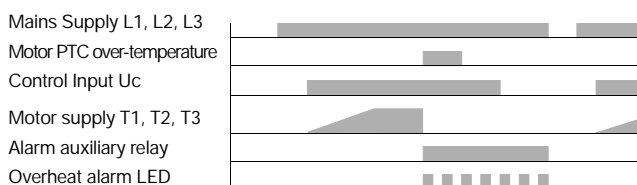

**Diagram 2c: Phase loss during power up**

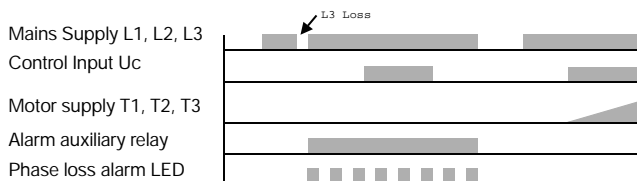

**Diagram 2d: Phase loss during ramping**

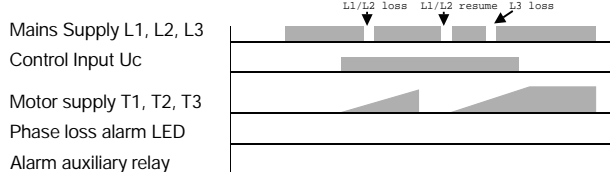

**Diagram 2e: Phase loss while bypass is ON**

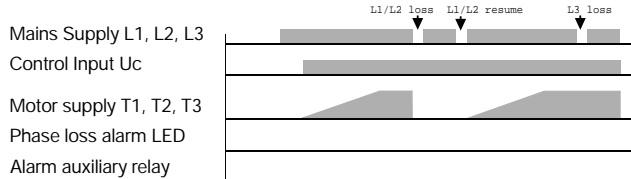

**Diagram 2f: Phase loss while bypass is being activated**

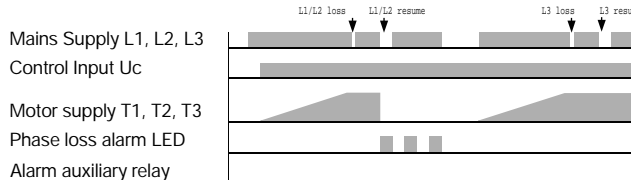

**Diagram 2g : Wrong phase sequence alarm**

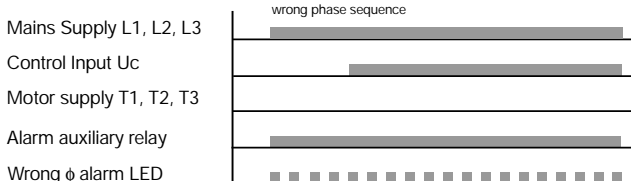

### Notes

Note 1: After activation of the by-pass relay, there is a delay of 1 sec, during which removal of the control input will not initiate the ramp-down function.

Note 2: Cycling of the control input should be limited to a rate not exceeding 3 seconds ON and 3 seconds OFF. At faster cycling times, it is not guaranteed that the output of the unit will respond to the given input.

Important: The number of starts per hour and Overload Cycle values should always be taken into consideration when cycling is used.

Note 3: Auxiliary relays available only on RSHR...V21 types

Note 4: A phase loss on L1 or L2 causes the device to reset as these phases provide the internal power supply.

Note 5: Phase sequence and phase loss alarms are only detected if they occur during power up, when L1, L2, L3 are switched ON.

Note 6: When a motor PTC is connected, electromagnetic noise may be conducted into the unit. Thus if abnormal function is observed, the use of ferrite beads on the PTC wire (at the unit end) is recommended.

Note 7: Repetitive voltage dips on phase L1 and/or L2 during operation may lead to overheating of the motor. In case the by-pass relays are activated and the repetition rate of these dips is such that the internal supply voltage falls below a preset limit, the by-pass relays will be automatically switched off. This state is indicated by blinking of the phase loss led at 1.3Hz. Reset of the supply L1, L2 and L3 is necessary to resume normal function.